

TOPIC 1 : EXPERIMENTAL TECHNIQUES

CHEMICAL WASTE

A chemical waste is a product or unwanted material from a chemical reaction or an expired product which is no longer needed for any experiment in the next activity.

EXAMPLES OF WASTE PRODUCTS FROM CHEMICAL REACTIONS

- Unused chemical e.g. acids, alkalis, solid chemicals etc
- Broken laboratory glassware, sharp objects
- Plastics, waste papers, and rubbers
- Poisonous gases from reactions

SAFE WAYS OF DISPOSING CHEMICAL WASTES

1. Use of normal waste bins.

This way can be used for wastes such as non-recycle plastics, pieces of wood, rubber and dirty papers.

2. Use of special controlled waste containers.

These are used to dispose sharp objects like scalpel, broken glass ware, sample tubes and items contaminated with hazardous chemicals. These must be emptied regularly and not allowed to overflow.

3. Draining using a lot of water.

Wastes which can be drained include harmless soluble inorganic salts, and contaminated and used acids and alkalis, detergents.

4. Recycling.

Recyclable materials include unbroken glass, packing waste and paper.

5. Incineration.



In this case the wastes are put into an incinerator and burned. Wastes that can be incinerated include syringes, needles, all organic solvents, soluble organic wastes, paraffin and mineral oils.

DESIGNING SCIENTIFIC INVESTIGATION

A scientific investigation is the systematic process of trying to find an answer or a solution to a problem or observation.

COMPONENTS OF A SCIENTIFIC INVESTIGATION

1. Problem identification

Identifying a problem involves asking questions about the natural world. Examples of scientific questions are:

- What causes rusting?
- Why do plastics not decompose easily?

2. Formulation of a hypothesis

A hypothesis is a guessed answer to a problem. A hypothesis is formulated from the scientist's experiences and knowledge.

3. Experimentation

An experiment is a series of investigations intended to accept, modify or reject a hypothesis.

4. Observation and data collection

This involves writing observations correctly, stating the correct units of each measurement. Scientific data is usually collected using tables.

5. Interpretation of data

Interpreting data means explaining the observations, trends in relation to the aim of the experiment.

6. Conclusion



The conclusion is drawn based upon the collected data. It is either a conformation or the rejection of the hypothesis under investigation. If the hypothesis is correct, it is confirmed and adopted and if false it is declared null and void hence rejected. When the hypothesis is rejected another one is formulated and tested.

PURITY OF A SUBSTANCE

A pure substance is a material that has constant composition and consistent properties throughout the sample. In other words, a pure substance does not contain impurities or any contaminants.

CRITERIA FOR PURITY

Chemists check whether a given substance is pure or not by carrying out a number of tests on the substance. The three basic tests carried out to check the purity of a substance are:

- a. Melting point
- b. Boiling point
- c. Paper chromatography

CHECKING PURITY OF A SUBSTANCE BY MELTING POINT

A pure substance has a specific melting point. The presence of impurities affects the melting point in two ways:

- Impurities lower the melting point of the substance. For example, pure ice melts completely at exactly 0°C but the ice we make at home from tap water will start to melt before 0°C.
- Impurities cause the substance to melt over a range of temperatures.

CHECKING PURITY OF A SUBSTANCE BY BOILING POINT

A pure substance has a fixed boiling point. The presence of impurities affects the boiling point in two ways:

- Impurities raise the boiling point of a substance. The more impurities the substance contains, the higher its boiling point will be.
- Impurities cause the substance to boil over a range of temperatures.



CHECKING PURITY OF A SUBSTANCE BY PAPER CHROMATOGRAPHY

Paper chromatography is used to separate mixtures of soluble substances. These are often coloured substances such as food colourings, inks, dyes or plant pigments.

In chromatography, substances are picked up and carried by a mobile phase which moves through a stationary phase.

The stationary phase

It is the part of the chromatography which is in solid state e.g. the filter paper.

The mobile phase

It is the part of the chromatography which is in gaseous or liquid state e.g. the solvent.

The different dissolved substances in the mixture are attracted to the two phases in different proportions. This causes them to travel at different rates through the paper.

Procedure

- Using a pencil, a 'start line' is drawn near the bottom of the chromatography paper.
- The mixture to be separated is spotted on the start line.
- The bottom of the chromatography paper is dipped into the solvent and the solvent travels up the paper.
- The solvent picks up the substance being tested and carries them up the paper.
- The different components in the substance rise to different heights.
- The "solvent front" is marked. The solvent front is the furthest point reached by the solvent on chromatography paper.

INTERPRETING CHROMATOGRAM

Chromatogram is the pattern formed by substances that have been separated by chromatography.

To determine purity of a substance, the chromatogram is interpreted as follows:

- A pure substance produces only one spot on the chromatogram.
- An impure substance produces two or more spots on the chromatogram.



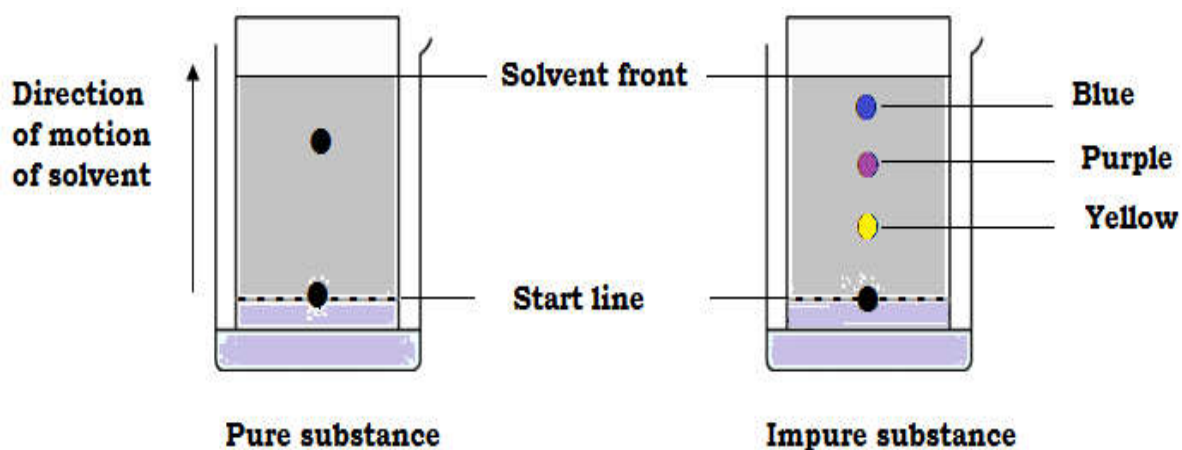

RELATIVE FLOW VALUES (R_f)

Relative flow value is the ratio of the distance travelled by the substance (spot) to the distance travelled by the solvent.

Mathematically;

$$\text{Relative flow value} = \frac{\text{Distance travelled by substance}}{\text{Distance travelled by solvent}}$$

Both distances are measured from the centre of the sample spot on the base line.

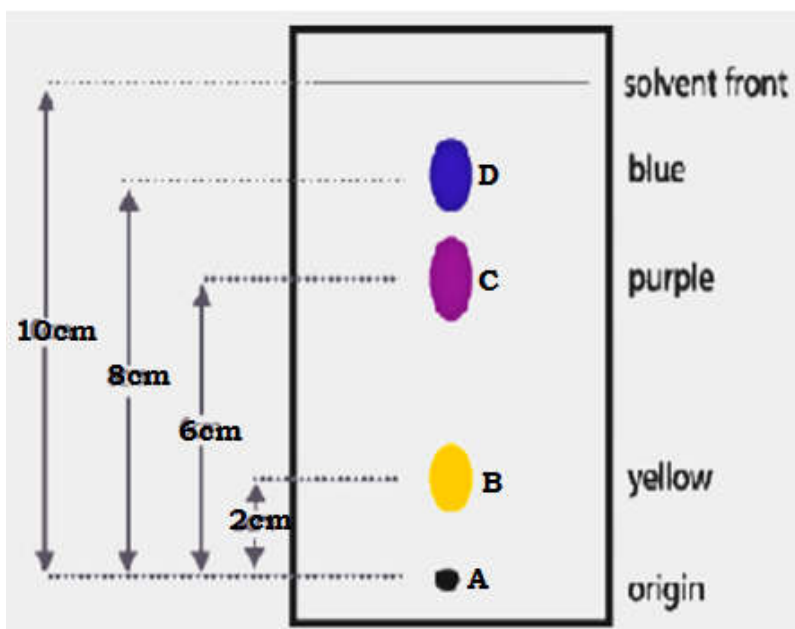

From this sample chromatogram, the relative flow values for components B, C and D are calculated as follows:

1. For component **B**, $R_f = \frac{8}{10} = 0.8$
2. For component **C**, $R_f = \frac{6}{10} = 0.6$
3. For component **D**, $R_f = \frac{2}{10} = 0.2$

The relative flow value is always less than 1 because the distance moved by spot is always less than the distance moved by solvent.

INTERPRETTING RELATIVE FLOW VALUES

The relative flow value can be used to identify the purity of a substance.

- A pure substance has only one relative flow value.
- An impure substance has more than one relative flow value.

TESTING FOR WATER, IONS AND GASES

Chemists carry out different chemical tests in order to find out the identity of a compound or a gas.

TEST FOR IONS

An ion is a charged atom. Ionic compounds consist of two kinds of ions: cations and anions. The positively charged ions are called **cations**. The negatively charged ions are called **anions**.

TESTING AQUEOUS CATIONS

The commonly tested cations are calcium (Ca^{2+}), aluminium (Al^{3+}), zinc (Zn^{2+}), copper (Cu^{2+}), iron (II), Fe^{2+} and iron (III), Fe^{3+} .

The aqueous cations can be identified using aqueous (dilute) sodium hydroxide and aqueous ammonia.

TESTING FOR AQUEOUS CATIONS USING AQUEOUS SODIUM HYDROXIDE



When aqueous sodium hydroxide solution is added to various salt solutions, most form precipitates and some soluble complex ions. A **precipitate** is an insoluble solid that emerges from a liquid solution.

Procedure

- Add a few drops of aqueous sodium hydroxide to the solution that contains the cation. Note and record the colour of any precipitate formed.

The table below shows expected colours of precipitates and their solubility in excess dilute sodium hydroxide.

Test substance	Cation	Observation after adding aqueous NaOH	
		3 drops	In excess
Copper sulphate	Cu^{2+}	Blue precipitate	Insoluble
Iron(II) chloride	Fe^{2+}	Pale green precipitate	Insoluble
Aluminium sulphate	Al^{3+}	White precipitate	White precipitate dissolves
Magnesium sulphate	Mg^{2+}	White precipitate	Insoluble
Calcium sulphate	Ca^{2+}	White precipitate	Insoluble
Zinc sulphate	Zn^{2+}	White precipitate	White precipitate dissolves

TESTING FOR CATIONS USING AQUEOUS AMMONIA

- Add a few drops of aqueous ammonia to the solution containing the cation.
- Note and record the colour of the precipitate formed.

The table below shows the expected colours of precipitates and their solubility in excess dilute ammonia.

Cation	Observation after adding aqueous ammonia (NH_3)	
	3 drops	In excess
Calcium (Ca^{2+})	White precipitate	Insoluble



Aluminium (Al^{3+})	White precipitate	Insoluble
Zinc (Zn^{2+})	White precipitate	Precipitate dissolves
Copper (Cu^{2+})	Blue precipitate	Precipitate dissolves
Iron (II) (Fe^{2+})	Green precipitate	Insoluble
Iron (III) (Fe^{3+})	Red brown precipitate	Insoluble
Lead (Pb^{2+})	White precipitate	Insoluble

TESTING FOR ANIONS

The commonly tested anions are sulphates, halides and nitrates.

a. TESTING FOR SULPHATE IONS (SO_4^{2-})

Add a few drops of dilute hydrochloric acid to the sample, followed by a few drops of barium chloride solution. A white precipitate forms if sulphate ions are present.

b. TESTING FOR HALIDE IONS

A halide ion is the halogen atom bearing a negative charge. For example, F^- , Cl^- , Br^- and I^- .

Add a few drops of dilute nitric acid to the sample, followed by a few drops of dilute silver nitrate solution. Observe and record the colour of any precipitate that forms.

The table below gives expected colours of precipitates with acidified silver nitrate.

Halide ion	Colour of precipitate
Fluoride ions (F^-)	No precipitate
Chloride ions (Cl^-)	White precipitate
Bromide ions (Br^-)	Pale yellow precipitate
Iodide ions (I^-)	Yellow precipitate

c. TESTING FOR NITRATES (NO_3^-)

Nitrate ions can be detected by reducing them to ammonia.

- To a little nitrate solution, add aqueous sodium hydroxide.
- Drop aluminium foil into the solution.
- Warm gently.

If nitrate ions are present, ammonia gas is given off. Ammonia gas turns damp red litmus paper blue.

TESTING FOR GASES

The commonly tested gases are ammonia, carbon dioxide, hydrogen, chlorine, oxygen and sulphur dioxide.

a. TESTING FOR AMMONIA (NH_3)

Introduce a damp red litmus paper into a jar containing ammonia. The damp red litmus paper turns blue if the gas is ammonia.

b. TESTING FOR CARBON DIOXIDE (CO_2)

Bubble the gas produced through lime water (calcium hydroxide solution). Lime water turns milky if the gas is carbon dioxide.

c. TESTING FOR HYDROGEN GAS (H_2)

Introduce a burning splint at the mouth of a gas jar containing hydrogen. The gas burns with a 'pop' sound if it is hydrogen.

d. TESTING FOR CHLORINE (Cl_2)

Hold a damp blue litmus paper at the mouth of a test tube containing chlorine gas. The damp blue litmus paper gets bleached if the gas is chlorine.

e. TESTING FOR OXYGEN GAS (O_2)

Introduce a glowing splint into a gas jar containing oxygen gas. The glowing splint relights (bursts into flames).



f. TESTING FOR SULPHUR DIOXIDE (SO₂)

Bubble the gas through acidified potassium dichromate (VII) solution. The acidified potassium dichromate (VII) changes from purple to colourless if the gas is sulphur dioxide.

TESTING FOR THE PRESENCE OF WATER

The presence of water can be tested using anhydrous copper (II) sulphate or anhydrous cobalt chloride.

a. ANHYDROUS COPPER (II) SULPHATE (CuSO₄) TEST FOR WATER

Anhydrous copper sulphate is white. When water is added to a sample of anhydrous copper sulphate, it turns blue. Change of colour from white to blue indicates that the added liquid is water.

b. ANHYDROUS COBALT (II) CHLORIDE (CoCl₂) TEST FOR WATER

Anhydrous cobalt (II) chloride is blue in colour. When water is added to a sample of anhydrous cobalt (II) chloride, it turns pink.



TOPIC 2 : NITROGEN, SULPHUR AND PHOSPHORUS

NITROGEN

- It is a group V element and is in period 2 of the Periodic Table.
- It has an atomic number is 7.
- Its electron configuration is 2.5
- It has a valency of 3. It can also exhibit a valency of 5.
- It makes about 78% of the air.

SOURCES OF NITROGEN

The following are some of the sources of nitrogen

- a. Air (atmosphere)
- b. The earth's crust
- c. Lightning
- d. Proteins
- e. Amino acids
- f. Leguminous plants e.g. groundnuts, pigeon peas.
- g. Fertilizers e.g. ammonium nitrate (NH_4NO_3), ammonium phosphate, $(\text{NH}_4)_3\text{PO}_4$ and sodium nitrate (NaNO_3).

PHYSICAL PROPERTIES OF NITROGEN

- It is colourless.
- It is odourless.
- It is insoluble in water.
- It is less dense than air.

CHEMICAL PROPERTIES OF NITROGEN

Nitrogen is a diatomic gas that has strong triple covalent bonds ($\text{N} \equiv \text{N}$) between the atoms of its molecules. These bonds require a lot of energy to break. The strong bonds make nitrogen to be unreactive (inert) under normal conditions.



However under very high temperatures it can react with other elements such as alkali metals, alkaline earth metals and hydrogen.

Examples are shown below:

1. Nitrogen reacts with alkali metals at high temperatures

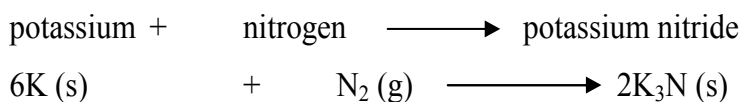

2. Nitrogen reacts with alkaline earth metals

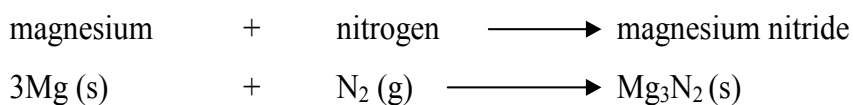

3. Nitrogen reacts with hydrogen to produce ammonia

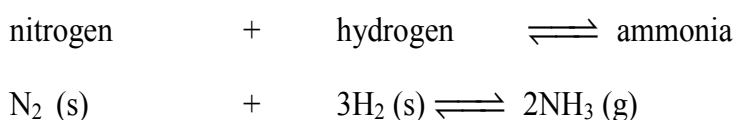

The double arrow (\rightleftharpoons) means that the reaction is reversible.

USES OF NITROGEN

- a. It is used in the production of ammonia
- b. It is used in food preservation.
- c. It is used in oil tankers to prevent fires because of its inertness.
- d. Liquid nitrogen is used as a refrigerant that is a very low-temperature coolant.
- e. Liquid nitrogen is used to shrink-fit machine parts.

COMPOUNDS OF NITROGEN

The compounds of nitrogen include the following:

- Ammonia (NH_3)
- Nitric acid (HNO_3)
- Oxides of nitrogen such nitrogen monoxide (NO) and nitrogen dioxide (NO_2).

PREPARATION OF AMMONIA



Ammonia can be prepared by heating any ammonium salt, such as ammonium chloride with an alkali, such as calcium hydroxide.

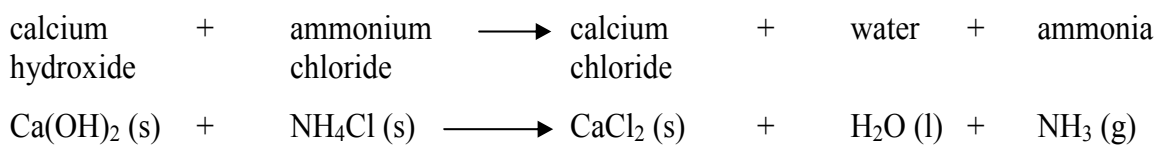

Water vapour is removed from the ammonia gas by passing the gas formed through a drying tower containing calcium oxide.

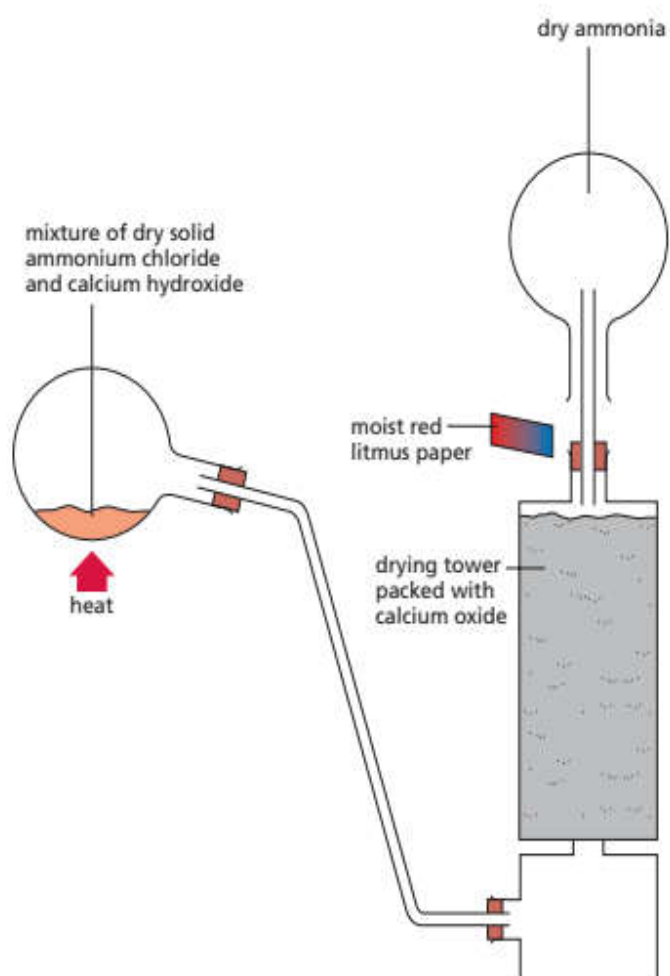

PROPERTIES OF AMMONIA

- It is colourless
- It has a pungent (choking) smell
- It is very soluble in water.
- It turns blue litmus paper red. This tells us that ammonia is a basic substance.

e. It reacts with hydrogen chloride gas to form a white smoke. The smoke is made of tiny particles of solid ammonium chloride.

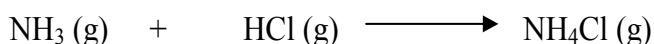

f. It reacts with acids to form salts. For example it reacts with nitric acid to form ammonium nitrate.

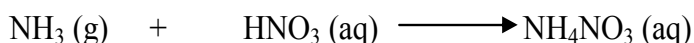

USES OF AMMONIA

- It is used in making nitric acid.
- Used in making plastics.
- Used in the manufacture of fertilizers.
- It is used to make hard water soft.
- It is used in the manufacture of ammonium chloride used in dry cells.
- Used in making explosives.

PREPARATION OF NITRIC ACID

Nitric acid can be prepared by heating potassium nitrate with concentrated sulphuric acid. The reaction for the process is:

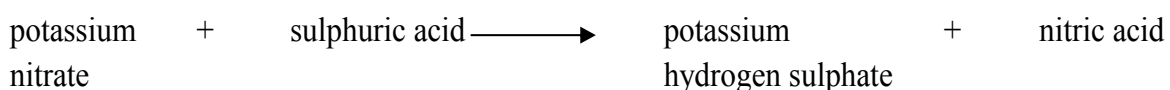

USES OF NITRIC ACID

- Used for making nitrate fertilizers.
- Used to manufacture explosives e.g. TNT and dynamite.
- Used to manufacture plastics.
- Used in the purification of metals e.g. silver, gold, platinum etc.
- Used to manufacture dyes and drugs.
- Used as an oxidizing agent in textile industries.
- Used in refining gemstones.



SULPHUR

- It is a group VI and period 3 element of the Periodic Table.
- It has an atomic number of 16.
- Its electron configuration is 2.8.6.

SOURCES OF SULPHUR

- Volcanic regions
- Crude oil
- Metal ores
- Natural gas in form of hydrogen sulphide (H_2S)

PHYSICAL PROPERTIES OF SULPHUR

- It is a brittle yellow substance.
- It is made up of crown shaped molecules, each containing eight atoms, S_8 .

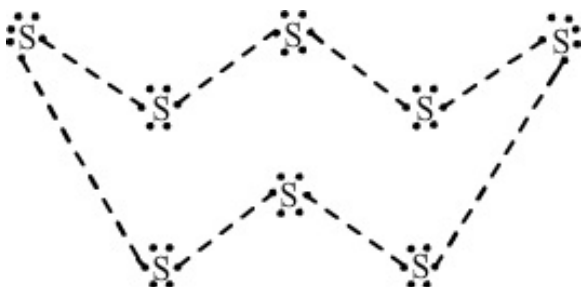

- It is insoluble in water.
- It is soluble in organic solvents such as methylbenzene and carbon disulphide.
- It has a low melting point.
- It does not conduct heat and electricity.
- It has two allotropes: rhombic and monoclinic sulphur.

CHEMICAL PROPERTIES OF SULPHUR

- It reacts with metals to form sulphides.

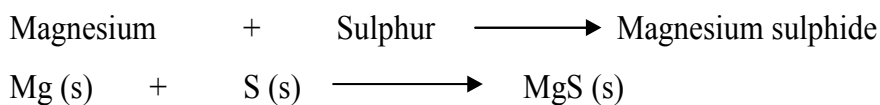

- It burns in oxygen to produce sulphur dioxide.

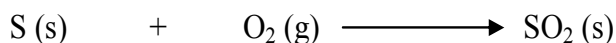

USES OF SULPHUR

Sulphur is used to:

- Produce sulphuric acid.
- Vulcanise rubber. Vulcanisation is the addition of sulphur to rubber in order to strengthen it.
- Make matches, pesticides, drugs and paper.
- Make sulphur concrete.
- Manufacture gun powder.
- Manufacture plastic flowers.

PRODUCTION OF SULPHURIC ACID

Sulphuric acid (H_2SO_4) is produced by the **contact process**. The process has the following steps:

- a. Sulphur is burnt in oxygen to produce sulphur dioxide.

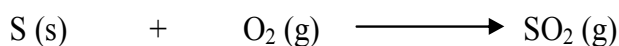

- b. Sulphur dioxide is reacted with oxygen to produce sulphur trioxide.

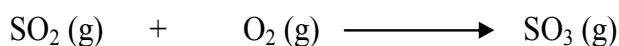

- c. Sulphur trioxide is mixed with concentrated sulphuric acid to produce oleum.

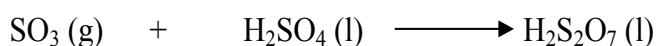

- d. The oleum is added to water to produce sulphuric acid.

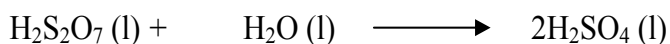

USES OF SULPHURIC ACID

Sulphuric acid is used:

- To manufacture inorganic fertilizers such as ammonium sulphate.
- To make paints and dyes.
- In the production of synthetic fibres e.g. nylon.



- As an acid in car batteries.
- To make soaps and detergents.
- In petroleum refining.
- As dehydrating agent. A **dehydrating agent** is a substance that removes water from another substance. The dehydration of sucrose is shown in the equation below.

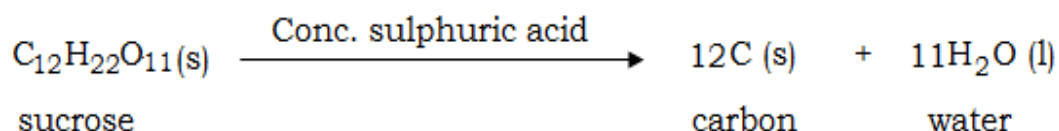

PHOSPHOROUS

- It is a group V and period 3 element of the Periodic Table.
- Its atomic number is 15.
- Its electron configuration is 2.8.5.
- It has a valency of 3 but it can also exhibit a valency of 5.

SOURCES OF PHOSPHOROUS

- Bones
- Banana peels
- Composite farm manure
- Crab shells
- Eggs
- The earth's crust in form of phosphates
- Mineral rocks mainly phosphates

PHYSICAL PROPERTIES OF PHOSPHOROUS

- It is a yellow solid at room temperature.
- It does not conduct heat or electricity.
- It has two allotropes: white and red phosphorous.
- It is insoluble in water.
- It has a melting point of 44°C and a boiling point of 280°C.



CHEMICAL PROPERTIES OF PHOSPHOROUS

- It reacts with oxygen to form oxides such as phosphorous pentaoxide and phosphorous trioxide.
- It combines easily with halogens.
- It reacts with metals.

USES OF PHOSPHOROUS

Phosphorous is used:

- To manufacture inorganic fertilizers such as ammonium phosphate.
- In the production of phosphoric acid.
- To make matches.
- To make toothpaste, detergents and baking powder.



TOPIC 3 : CHEMICAL BONDING AND PROPERTIES OF MATTER

PHYSICAL PROPERTIES OF IONIC COMPOUNDS

- They are made up of ions and not atoms nor molecules.
- They have strong electrostatic forces.
- They are soluble in water.
- They are insoluble in organic solvents like benzene or propanone.
- They have high melting and boiling points.
- They are hard brittle solids at room temperature.
- They conduct electricity when in molten or aqueous state. Molten state means “when melted” while aqueous state means “when dissolved in water”.

PHYSICAL PROPERTIES OF COVALENT COMPOUNDS

- They are made up of molecules and not ions.
- They low intermolecular forces.
- Most are insoluble in water.
- They are soluble in organic solvents like benzene and propanone.
- They have low melting and boiling points.
- Most are gases or volatile liquids at room temperature.

STRUCTURAL DIFFERENCES BETWEEN IONIC AND COVALENT COMPOUNDS

1. STRUCTURE OF IONIC COMPOUNDS

The ions in the compound are arranged in a regular pattern. Cations and anions are alternated. The pattern repeats several times. The result is a crystal **lattice**. The oppositely charged ions are held by strong ionic bonds, forming a **giant structure**. An example of a giant structure of sodium chloride is shown below.



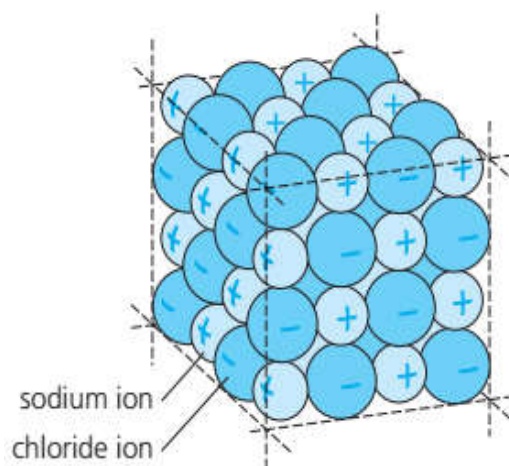

EFFECTS OF STRUCTURES ON THEIR PHYSICAL PROPERTIES

- The strong electrostatic attraction between the ions in the structure requires a lot of heat to break down. This causes ionic compounds to have high melting and boiling points.
- In solid state, ionic compounds do not conduct electricity. This is because the ions are locked in fixed positions crystal lattice and are not able to move freely. However, when in molten state or in aqueous solution ionic compounds conduct electricity because the crystalline structure is broken down and the ions are free to move and conduct electric current.

An aqueous solution that conducts electricity is called an electrolyte. For this reason, ionic compounds are said to be **electrolytes**.

2. STRUCTURES OF SIMPLE COVALENT COMPOUNDS

In simple covalent compounds, the atoms forming the molecules are held by strong covalent bonds. However, the molecules are attracted by weak intermolecular force called van der Waal's forces or hydrogen bonds.

EFFECTS OF SIMPLE COVALENT STRUCTURES ON THEIR PHYSICAL PROPERTIES

- The weak intermolecular forces cause simple covalent compounds to have low melting and boiling points. When heated, they melt quickly or vapourise.
- Since their structure do not contains ions, covalent compounds do not conduct electricity. They are non-electrolytes.

DISTINGUISHING IONIC AND COVALENT SOLUTIONS USING CONDUCTIVITY

Materials

2 cells, a bulb (3.8V, 0.3A), 3 connecting wires fitted with crocodile clips, iron nails or graphite rods, 40 ml of each of the following; sodium chloride solution, sugar solution, dilute sulphuric acid and ethanol, distilled water and a beaker (100 ml)

a. Set up the apparatus as shown below

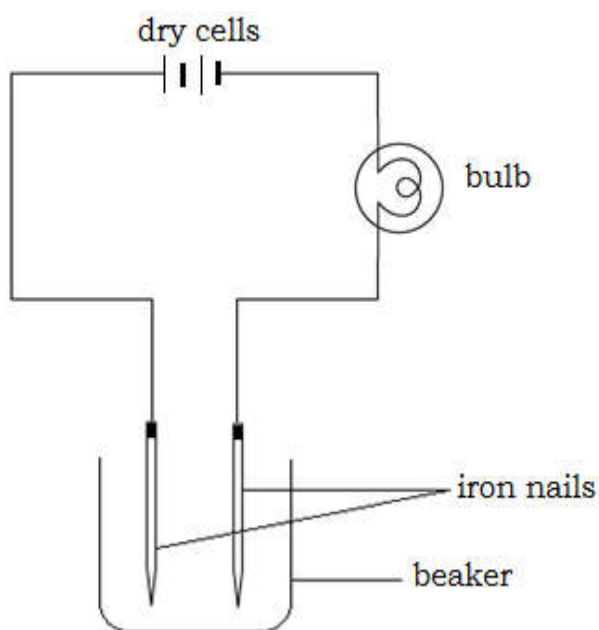

- Pour 40 ml of sodium chloride solution into the beaker
- Dip the nails into the solution
- Observe the bulb and record “light” or “no light” in the table of results.
- Remove the nails from the beaker.
- Rinse the beaker and the nails with distilled water.
- Repeat steps **b** to **f** using sugar solution, dilute sulphuric acid and ethanol.

Table of results

Liquid	Observation
Sodium chloride	
Sugar solution	
Sulphuric acid	
Ethanol	

h. Classify the liquids as ionic or covalent.

HINT

When the bulb gives light, the liquid used is ionic and when the bulb does not give light, the liquid use is covalent.

COMMON EXAMPLES OF ELECTROLYTES AND NON-ELECTROLYTES

Electrolytes	Non-electrolytes
Sodium chloride solution	Pure water
Copper (II) sulphate solution	Sugar solution
Sodium hydroxide solution	Paraffin wax
Hydrochloric acid	Ethanol
Sulphuric acid	Urea
Ethanoic acid	Molten sulphur

PURE COVALENT BONDS AND DATIVE COVALENT BONDS

a. Pure covalent bond

It is a covalent bond whereby the shared pair of electrons are equally donated by the atoms involved. For example, the bonding in ammonia, NH_3 is pure covalent bonding because both hydrogen and nitrogen contribute an electron to the shared pair.

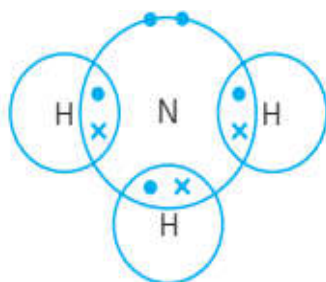

A molecule of ammonia

b. Dative covalent bond

It is a covalent bond whereby only one atom contributes all the shared pair of electrons. A very good example of dative bonding occurs in the formation of ammonium ion, NH_4^+ .

Nitrogen atom in the molecule of ammonia donates a lone pair of electrons to hydrogen ion, H^+

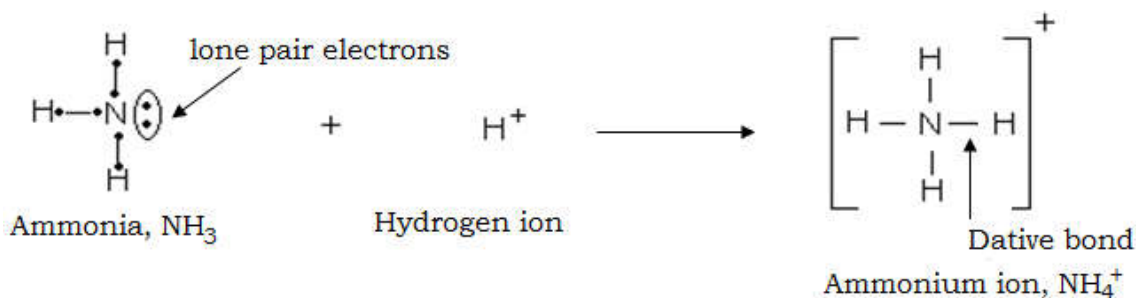

POLAR AND NON-POLAR COVALENT BONDS

a. Polar covalent bond

A polar covalent bond is formed when electrons are not shared equally between atoms. This happens when the atoms have electronegativity differences. Electrons are attracted to the more electronegative atom. The more electronegative atom acquires a **partial negative charge** (symbolized δ^-) and the less electronegative atom acquires a **partial positive charge** (symbolized δ^+). The bond between two polar molecules is called a **dipole**.

Molecules that have **partial charges** are called **polar covalent molecules**. The existence of partial charges in some covalent compounds enables them to conduct electricity in aqueous solutions. A good example of polar covalent compound is hydrogen chloride (HCl).

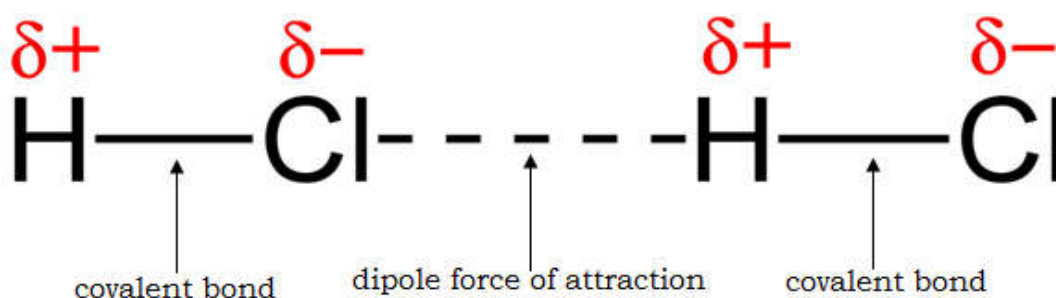

b. Non-polar covalent bond

A non-polar covalent bond is formed when electrons are equally shared between atoms. This happens when atoms have the same electronegativity such as in hydrogen ($H-H$) molecule and a chlorine ($Cl-Cl$) molecule. Molecules that have non-polar bonds are called **non-polar covalent molecules**. They do not have partial charges as a result they do not conduct electricity.

TYPES OF INTERMOLECULAR FORCES

There are two types of intermolecular forces; hydrogen bonds and van der Waal's forces. These bonds are generally weak.

a. Hydrogen bonding

This type of bonding occurs between molecules containing hydrogen and a more electronegative atom than the hydrogen atom. The attraction between the partially negative atom and the partially positive atom is called the hydrogen bond.

b. Van der Waals Forces

These are weak attractive or repulsive forces between and outside molecules. Van der Waals forces are present in most molecules.

EFFECTS OF INTERMOLECULAR FORCES ON PHYSICAL PROPERTIES

- Water has a higher boiling point when compared to many covalent compounds because of the presence of hydrogen bonds between its molecules.
- Surface tension of water is great due to hydrogen bonding among water molecules.
- The presence of hydrogen bonds between water molecules gives it its liquid state.
- Van der Waals force significantly to higher boiling points for some elements such as halogens.

ALLOTROPY

This is the existence of an element in more than one form in the same state. The different forms of the same element which exist in the same physical state are called **allotropes**. Oxygen has two allotropes; oxygen and ozone. Sulphur has two allotropes; rhombic and monoclinic. Carbon has two allotropes; graphite and diamond.

STRUCTURE OF GRAPHITE

In graphite, each carbon atom forms covalent bonds to three others. This gives rings of six atoms. The rings form flat sheets that can slide over each other easily.



The sheets are held together by weak forces.

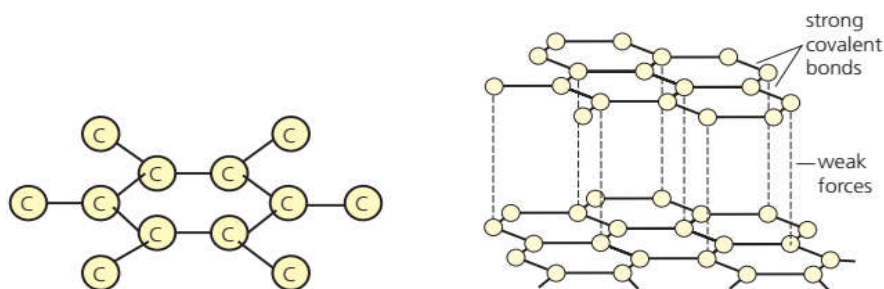

PHYSICAL PROPERTIES OF GRAPHITE

- It is soft and slippery.
- Dark grey in colour
- It conducts electricity. This is because each carbon atom has four valence electrons but only forms three bonds. So, the fourth electron is free to move through the graphite, carrying charge.

USES OF GRAPHITE

- Used as a lubricant for engines and locks.
- It is mixed with clay to make pencil lead.
- Used as electrode in electric circuits.
- Used for connecting brushes in generators.

STRUCTURE OF DIAMOND

In diamond, each carbon atom forms four covalent bonds to four others. The four carbon atoms are arranged in a tetrahedral structure. This makes the structure very strong and rigid, which melts at 3550°C.

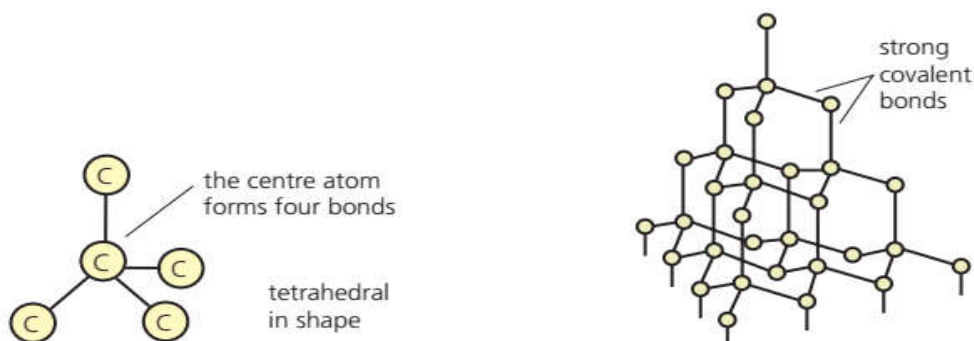

PHYSICAL PROPERTIES OF DIAMOND

- It is the hardest substance on earth ever known.
- It is a colourless substance.
- Its sparkles in light when cut.
- It does not conduct electricity.

USES OF DIAMOND

- Used for making jewellery e.g. necklace, rings, and earrings. This is because of its attractive appearance.
- Used to make drilling equipment and cutting tools because it is very hard.

SILICON DIOXIDE (SILICA)

Silicon dioxide (SiO_2) occurs naturally as **quartz**, the main mineral in sand. Like diamond, silicon dioxide forms a giant structure shown below.

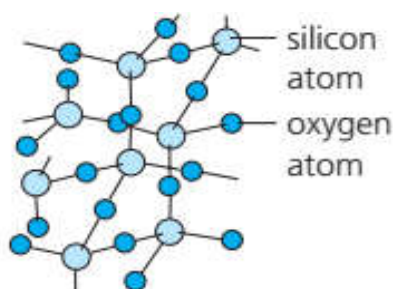

In silicon dioxide, each silicon atom forms four covalent bonds with oxygen atoms and each oxygen atom bonds covalently to two silicon atoms. The result is a very hard substance with a melting point 1710°C . The table below compares the properties of diamond and silicon dioxide.

Property	Diamond	Silicon dioxide
Hardness	Hardest substance on earth	Very hard substance
Conductivity	Does not conduct electricity	Does not conduct electricity
Melting point	Very high melting point, 3550°C	High melting point, 1710°C

PROPTERIES OF METALS

- They have high melting and boiling points. This is due to the strong metallic bonds between the positive metal ions and the mobile sea of electrons.
- They have high densities because the atoms are very closely packed.
- They are ductile i.e. they can be drawn out into thin wires.
- They are malleable i.e. they can be hammered into different shapes.
- They are sonorous i.e. they produce a ringing sound.
- They are shiny.
- They are good conductors of heat. This is because they have free electrons which transfer the heat through the metal structure.
- They are good conductors of electricity due to the free electrons within the metal structure. These mobile electrons carry charge when a voltage is applied across the metal.

USES OF METALS IN RELATION TO THEIR PROPERTIES

Property	Uses
Good electrical conductors	Used in electrical wiring and in appliances such as TVs, radios, computers
Good thermal conductors	Used to make cooking utensils e.g. pots
Malleable	Used to make shaped objects e.g. car bodies, kitchen ware etc.
Ductile	Use to make connecting wires e.g. copper wire
Sonorous	Used to make bells
Shiny	Used to make jewellery e.g. earrings, bangles and necklaces.

ALLOYS

An alloy is a mixture of two or more elements one whereby atleast one of them is a metal.

EXAMPLES OF ALLOYS

- a. Stainless steel. It is a combination of iron (metal) and chromium (metal).
- b. Brass. It is a mixture copper (metal) and zinc (metal).



c. Bronze. It is a combination of copper (metal) and tin (metal).

PROPERTIES AND USES OF ALLOYS

Alloy	Composition	Properties	Used to make
Brass	70% copper 30% zinc	<ul style="list-style-type: none"> • Harder than pure copper • Gold coloured 	<ul style="list-style-type: none"> • Kitchenware • Musical instruments • Screw • Radiators
Stainless steel	74% iron 18% chromium 8% carbon	<ul style="list-style-type: none"> • Shiny • Strong • Doesn't rust 	<ul style="list-style-type: none"> • Cutlery • Surgical instruments • Kitchen sinks
Steel	99% iron 1% carbon	<ul style="list-style-type: none"> • Hard and strong 	<ul style="list-style-type: none"> • Bridges and bridges • Body of cars and railway tracks
Bronze	90% copper 10% tin	<ul style="list-style-type: none"> • Hard and strong • Has shiny surface • Doesn't rust easily 	<ul style="list-style-type: none"> • Statues and monuments • Medals, swords and artistic materials



TOPIC 4 : STOICHIOMETRY

CHEMICAL FORMULAE OF COMPOUNDS

The formula of a compound is made up from the symbols of the elements present and numbers to show the ration in which the different atoms are present.

STEPS TO BE FOLLOWED IN WRITING CHEMICAL FORMULAE

In order to write a correct chemical formula of a compound, the following steps can be used.

- Write down the correct symbol of the elements.
- Write down the valency of each element.
- Exchange the valencies of the elements.
- Write down the exchanged valencies as subscripts in the formula.

Examples

Write down the formula of each of the following compounds given the valencies of each element.

a. sodium sulphate

Solution

Symbol	Na	SO ₄
Valency	1	2
Exchange the valencies	Na ¹	² SO ₄
The correct formulas is	Na₂SO₄	

b. Magnesium chloride

Solution

Symbol	Mg	Cl
Valency	2	1
Formula	MgCl₂	



c. Calcium hydroxide

Solution

Symbol	Ca	OH
Valency	2	1
Formula	Ca(OH)₂	

d. Magnesium oxide

Solution

Symbol	Mg	O
Valency	2	2
Formula	Mg ₂ O ₂ which is often simplified to MgO	

CHEMICAL EQUATIONS

A chemical equation is a shorthand way representation of what happens in a chemical reaction.

Example

Magnesium reacts with oxygen to form magnesium oxide. Write a chemical equation for this reaction.

SOLUTION

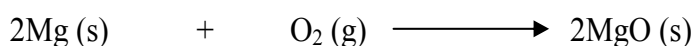

IMPORTANT FACTS ABOUT CHEMICAL EQUATIONS

- Reactants and products are separated by an arrow.



Reactants are always written on the left hand side while products are written on the right hand side of the arrow.

- The plus (+) sign in chemistry when used on the left hand side of the arrow means “reacts with”.



- The arrow means “to form” the products on the right.
- A double arrow (\rightleftharpoons) means that the reaction is reversible.

BALANCING CHEMICAL EQUATIONS

Balancing a chemical equation means ensuring that there is an equal number of atoms of each element on either side of the equation.

GUIDELINES FOR BALANCING CHEMICAL EQUATIONS

1. Write down the correct formulae for each substance.
2. Balance the atoms on both sides of the equation by multiplication of molecules of reactants or products.
3. Do not change the formula of a substance or element in order to balance the equation.
4. In the brackets, after each substance write down its physical state.

The following are the short forms for different physical states which are commonly used in chemical equations.

Physical state	State symbol
solid state	(s)
liquid state	(l)
gaseous state	(g)
aqueous solution	(aq)

METHODS OF BALANCING CHEMICAL EQUATIONS

There are two methods of balancing chemical equations: **trial and error** method and the **systematic method**. In this book we will use the systematic method to balance equations.

Example 1

Balance the equation $\text{C}_3\text{H}_8 (\text{g}) + \text{O}_2 (\text{g}) \longrightarrow \text{CO}_2 (\text{g}) + \text{H}_2\text{O} (\text{l})$

Solution

Let the balanced equation be

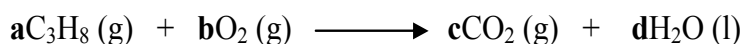

Using **C** atoms only

$$3a = c \dots\dots\dots[1]$$

Using **H** atoms only

$$8a = 2d \dots\dots\dots[2]$$

Using **O** atoms only

$$2b = 2c + d \dots\dots\dots[3]$$

Solving the equations

Let **a** = **1**. Then use this assumption to solve for all the equations using substitution method.

$$c = 3a = 3(1) = 3$$

$$2d = 8a = 8(1)$$

$$d = \frac{8}{2} = 4$$

$$2b = 2(3) + 4$$

$$b = \frac{10}{2} = 5$$

The balanced equation is therefore

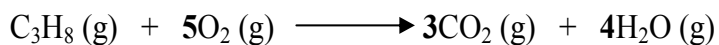

Example 2:

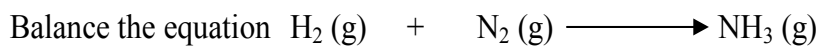

Solution

Let the balanced equation be



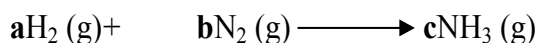

Using H atoms only

$$2a = 3c \dots\dots\dots [1]$$

Using N atoms only

$$2b = c \dots\dots\dots [2]$$

Let $a = 1$, then $c = \frac{2}{3}$ and $b = \frac{1}{3}$.

The balanced equation becomes

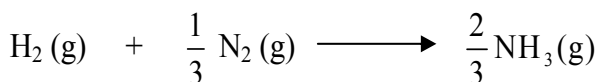

The coefficients must be whole numbers; therefore the whole equation is multiplied by 3 to remove the fractions:

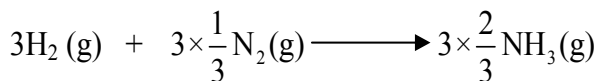

Finally the balanced equation is

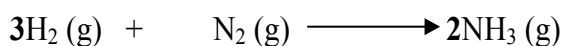

RELATIVE FORMULA MASS (R.F.M) OF A COMPOUND

The relative formula mass (RFM) of a compound is the sum of the relative atomic masses (RAM) of atoms in the numbers shown in the formula. Both relative atomic and formula masses have the same units. The unit is the atomic mass unit (**amu**).

CALCULATING RELATIVE FORMULA MASS OF COMPOUNDS

To calculate the relative formula mass of a compound, add the relative atomic masses for all the atoms present in that compound.



Example 1

Work out the relative formula mass (R.F.M) of ethanol ($\text{CH}_3\text{CH}_2\text{OH}$).

(RAM of C =12, H = 1 and O = 16).

Solution

$$\begin{aligned}\text{R.F.M of CH}_3\text{CH}_2\text{OH} &= (12 \times 2) + (1 \times 6) + (16 \times 1) \\ &= 24 + 6 + 16 \\ &= 46 \text{ amu}\end{aligned}$$

Example 2

Work out the relative formula mass (R.F.M) of aluminium sulphate, $\text{Al}_2(\text{SO}_4)_3$.

(RAM of Al = 27, S = 32, and O = 16)

Solution

$$\begin{aligned}\text{RFM of Al}_2(\text{SO}_4)_3 &= (27 \times 2) + (32 \times 3) + (16 \times 4 \times 3) \\ &= 54 + 96 + 192 \\ &= 342 \text{ amu}\end{aligned}$$

THE MOLE

The mole refers to an amount of a substance containing 6.023×10^{23} particles. The mole is a unit of measurement just like “pair”, “dozen”, “ream” among others. The number 6.023×10^{23} is called **Avogadro’s constant**.

The particles in moles could be atoms, molecules, ions and electrons. For example

$$1 \text{ mole of hydrogen atoms} = 6.023 \times 10^{23} \text{ H atoms.}$$

$$1 \text{ mole of potassium atoms} = 6.023 \times 10^{23} \text{ K atoms}$$



1 mole of oxygen molecules = 6.023×10^{23} O₂ molecules

1 mole of copper ions = 6.023×10^{23} Cu²⁺ ions

1 mole of electrons = 6.023×10^{23} electrons

RELATIONSHIP BETWEEN MOLE AND MASS OF A SUBSTANCE

1 mole of the particles of any substance is equivalent to the relative atomic mass (RAM) of the atom in the molecule of the substance expressed in grams.

For example, the relative atomic mass of sodium (Na) is 23 amu. Therefore, 1 mole of sodium atoms weighs 23g. Similarly, 23g of sodium atoms contains 6.023×10^{23} sodium atoms.

MOLAR MASS

It is the mass of one mole of a substance. It is simply the relative atomic mass (RAM) of an atom or the relative formula mass (RFM) of a compound expressed in grams. The unit of molar mass is the **gram per mol**. It is denoted as g/mol or gmol⁻¹.

MOLE CALCULATIONS

a. CONVERTING MASS INTO MOLES

Number of moles = $\frac{\text{Mass of substance}}{\text{Molar mass}}$

Example 1

Work out the number of moles of aluminium (Al) present in 108g of the substance.

(RAM of Al = 27)

Solution

Number of moles = $\frac{108\text{g}}{27\text{g/mol}}$
= 4 moles



Example 2

Calculate the number of moles present in 19.6g of sulphuric acid (H₂SO₄). (RAM of H = 1, S = 32 and O = 16).

Solution

$$\text{Molar mass of H}_2\text{SO}_4 = (1 \times 2) + (32 \times 1) + (16 \times 4)$$

$$= 98\text{g/mol}$$

$$\text{Number of moles} = \frac{19.6\text{ g}}{98\text{ g/mol}}$$

$$= 0.2\text{ mole}$$

b. CONVERTING MOLES INTO MASS

$$\text{Mass of a substance} = \text{Number of moles} \times \text{molar mass}$$

Example 1

How many grams are there in 2 moles of iron (Fe)? (RAM of Fe = 56).

Solution

$$\text{Mass of iron} = 2\text{ moles} \times 56\text{g/mol}$$

$$= 112\text{g.}$$

Example 2

Calculate the mass of 0.25 mole of ethanol (CH₃CH₂OH). (RAM of C = 12, H = 1 and O = 16).

Solution

$$\text{Molar mass of ethanol} = (12 \times 2) + (1 \times 6) + (16 \times 1)\text{ g/mol} = 46\text{g/mol}$$

$$\text{Mass of ethanol} = 0.25\text{ mole} \times 46\text{g/mol}$$

$$= 11.5\text{g}$$



c. USING AVOGADRO'S CONSTANT TO FIND THE NUMBER OF PARTICLES IN A GIVEN SUBSTANCE

Number of particles = Avogadro's constant \times Number of moles

The Avogadro's constant is denoted as $L = 6.023 \times 10^{23}$ particles.

Example 1

Find the number of atoms in 3 moles of iron (Fe). ($L = 6.023 \times 10^{23}$ particles)

Solution

$$\begin{aligned} \text{Number of Fe atoms} &= 3 \text{ moles} \times 6.023 \times 10^{23} \text{ atoms} \\ &= 1.8069 \times 10^{24} \text{ atoms.} \end{aligned}$$

Example 2

If 54g of aluminium were collected from aluminium ore, how many atoms of aluminium were collected? (RAM of Al = 27, $L = 6.023 \times 10^{23}$ particles).

Solution

$$\begin{aligned} \text{Number of moles of Al} &= \frac{54 \text{ g}}{27 \text{ g/mol}} \\ &= 2 \text{ moles} \\ \text{Number of atoms of Al} &= 2 \text{ moles} \times 6.023 \times 10^{23} \text{ atoms} \\ &= 1.2046 \times 10^{24} \text{ atoms.} \end{aligned}$$

Example 3

How many ions are there in 13g of potassium ions (K^+). (RAM of K = 39, $L = 6.023 \times 10^{23}$ particles).

Solution



$$\text{Number of moles of K}^+ \text{ ions} = \frac{13 \text{ g}}{39 \text{ g/mol}}$$

$$= 0.333 \text{ mole}$$

$$\text{Number of K}^+ \text{ ions} = 0.333 \text{ mole} \times 6.023 \times 10^{23} \text{ ions}$$

$$= 2.005659 \times 10^{23} \text{ ions.}$$

MOLAR GAS VOLUME

Molar gas volume is the volume occupied by 1 mole of a gas.

It is 24 dm³ room temperature and pressure (r.t.p). Room temperature and pressure are 25°C (298K) and 1 atmosphere respectively. It is 22.4 dm³ at standard temperature and pressure (s.t.p). Standard temperature and pressure are 0°C (273K) and 1 atmosphere respectively.

The molar volume is true for any kind of a gas. It does not matter whether the gas exists as atoms or molecules, or whether its atoms are large or small.

CALCULATIONS INVOLVING MOLAR VOLUME

At r.t.p:

$$\text{Number of moles of a gas} = \frac{\text{Volume of gas}}{24 \text{ dm}^3}$$

$$\text{Volume of gas} = \text{Number of moles} \times 24 \text{ dm}^3$$

At s.t.p:

$$\text{Number of mole of a gas} = \frac{\text{Volume of gas}}{22.4 \text{ dm}^3}$$

$$\text{Volume of gas} = \text{Number of moles} \times 22.4 \text{ dm}^3$$

Example 1

Work out the number of moles of carbon dioxide (CO₂) contained in 60 dm³ of carbon dioxide measured at room temperature and pressure (r.t.p).



Solution

$$\begin{aligned}\text{Number of moles} &= \frac{\text{Volume of carbon dioxide}}{24 \text{ dm}^3} \\ &= \frac{60 \text{ dm}^3}{24 \text{ dm}^3} \\ &= 2.5 \text{ moles}\end{aligned}$$

Example 2

How many moles are there in 24 cm^3 of hydrogen (H_2) at room temperature and pressure?

Solution

First, convert 24 cm^3 into cubic decimeters.

$$\begin{aligned}24 \text{ cm}^3 &= \frac{24}{1000} \text{ dm}^3 \\ &= 0.024 \text{ dm}^3\end{aligned}$$

$$\begin{aligned}\text{Number of moles} &= \frac{\text{Volume of hydrogen}}{24 \text{ dm}^3} \\ &= \frac{0.024 \text{ dm}^3}{24 \text{ dm}^3} \\ &= 0.001 \text{ mole}\end{aligned}$$

Example 3

What volume (in cm^3) does 0.25 mole of oxygen occupy at standard temperature and pressure?

Solution

$$\begin{aligned}\text{Volume of gas} &= \text{Number of moles} \times 22.4 \text{ dm}^3 \\ &= 0.25 \times 22.4 \text{ dm}^3 \\ &= 5.6 \text{ dm}^3\end{aligned}$$



$$\begin{aligned} \text{Volume in cm}^3 &= 5.6 \times 1000 \\ &= 5600 \text{ cm}^3 \end{aligned}$$

Example 4

What volume does 22 g of carbon dioxide occupy at room temperature and pressure? (RAM of C = 12 and H = 1).

Solution

$$\begin{aligned} \text{Number of moles} &= \frac{\text{Mass of compound}}{\text{Molar mass}} \\ &= \frac{22 \text{ g}}{[(12 \times 1) + (16 \times 2)] \text{ gmol}^{-1}} \\ &= \frac{22 \text{ g}}{44 \text{ gmol}^{-1}} \end{aligned}$$

$$= 0.5 \text{ mole}$$

$$\begin{aligned} \text{Volume of gas} &= \text{Number of moles} \times 24 \text{ dm}^3 \\ &= 0.5 \times 24 \text{ dm}^3 \\ &= 12 \text{ dm}^3 \end{aligned}$$

WATER OF CRYSTALLIZATION

Water of crystallization refers to the water present in crystals of some salt compounds. Water of crystallization is also called **water of hydration**.

Salts containing water of crystallization are called **hydrates** or **hydrated compounds**. Some of the hydrates are shown in the table below.

Name of salt	Formula	Number of molecules of water of crystallization
Copper (II) sulphate pentahydrate	$\text{CuSO}_4 \cdot 5\text{H}_2\text{O}$	5



Magnesium sulphate heptahydrate	$\text{MgSO}_4 \cdot 7\text{H}_2\text{O}$	7
Sodium carbonate decahydrate	$\text{Na}_2\text{CO}_3 \cdot 10\text{H}_2\text{O}$	10
Cobalt (II) chloride hexahydrate	$\text{CoCl}_2 \cdot 6\text{H}_2\text{O}$	6

When hydrated salts are heated, they lose their water of crystallization. The resulting crystal is called **anhydrous**, meaning without water.

DETERMINING THE PERCENTAGE OF WATER IN MOLECULAR AND HYDRATED IONIC COMPOUNDS

The percentage of water in any molecular or hydrated ionic compound can be determined both experimentally and theoretically.

- Experimentally, the percentage of water in a hydrate is found by comparing the mass of water driven off, usually by heating, to the total mass of the compound.
- Theoretically, the percentage of water is found by dividing the water of crystallization relative formula mass by the relative formula mass of the hydrate.

Example 1

Calculate the percentage of water crystallization in sodium carbonate decahydrate ($\text{Na}_2\text{CO}_3 \cdot 10\text{H}_2\text{O}$). RAM of Na = 23, C = 12, O = 16 and H = 1).

Solution

$$\text{Relative formula mass of water} = (10 \times 18)$$

$$= 180 \text{ amu}$$

$$\text{Relative formula mass of } \text{Na}_2\text{CO}_3 \cdot 10\text{H}_2\text{O} = (23 \times 2) + (12 \times 1) + (16 \times 3) + 180$$

$$= 46 + 12 + 48 + 180$$

$$= 286 \text{ amu}$$



$$\begin{aligned}
 \text{Percentage of water} &= \frac{\text{mass of water crystallization}}{\text{mass of compound}} \\
 &= \frac{180}{286} \times 100\% \\
 &= 62.937\%
 \end{aligned}$$

Example 2

On heating 1.250 g hydrated barium chloride, 1.060 g of anhydrous barium chloride remained. Calculate the percentage of water of crystallization in the compound.

Solution

$$\begin{aligned}
 \text{Total mass of hydrate} &= 1.250 \text{ g} \\
 \text{Mass of anhydrous salt} &= 1.060 \text{ g} \\
 \text{Mass water of crystallization} &= \text{mass of hydrate} - \text{mass of anhydrous} \\
 &= 1.250 \text{ g} - 1.060 \text{ g} \\
 &= 0.19 \text{ g} \\
 \text{Percentage of water of crystallization} &= \frac{\text{mass of water}}{\text{mass of hydrate}} \\
 &= \frac{0.19}{1.250} \times 100 \\
 &= 15.2\%
 \end{aligned}$$

Experiment

Aim

To determine the percentage of water in hydrated copper sulphate

Materials



Hydrated copper sulphate, evaporating basin (tin), burner, triple beam balance, tripod stand and wire gauze.

Procedure

1. Weigh the tin on the triple beam balance and record its mass in the appropriate space in the table of results.
2. Add the crystals of hydrated copper sulphate until the reading increases by approximately 5g.
3. Record the mass of the tin plus the hydrated copper sulphate.
4. Find the mass of the hydrated copper sulphate.
5. Heat the tin gently until the hydrated copper sulphate turns into a white powder.
6. Weigh the tin plus white powder (anhydrous copper sulphate) and record the results in the appropriate space in the table.
7. Work out the mass of the white powder.
8. Find the mass of water lost.
9. Calculate the percentage of water in the hydrated copper sulphate.

Table of results

Item	Mass (g)
Tin	
Tin + hydrated copper sulphate	
Hydrated copper sulphate	
Tin + anhydrous copper sulphate	
Anhydrous copper sulphate	
Water lost	

- Mass of hydrated copper sulphate = mass of tin + hydrated copper sulphate – mass of tin
- Mass of anhydrous copper sulphate = mass of tin + anhydrous copper sulphate – mass of tin
- Mass of water lost = mass of hydrated copper sulphate – mass of white powder



EMPIRICAL AND MOLECULAR FORMULAE OF A COMPOUND

1. EMPIRICAL FORMULA

Empirical formula is the formula that contains the lowest number of atoms that make up a compound.

For example in the molecular formula of glucose, $C_6H_{12}O_6$ the ratio of atoms is 6:12:6. This can be simplified to 1:2:1. Therefore, the empirical formula of glucose would be written as CH_2O .

CALCULATING EMPIRICAL FORMULA

The empirical formula of any compound can be worked out from:

- mass composition of a compound
- percentage composition by mass of a compound

GENERAL GUIDELINES FOR CALCULATING EMPIRICAL FORMULA

- a. Convert mass of each element into moles.
- b. Convert the moles into simplest mole ratio.
- c. Write the empirical formula using simplest mole ratio.

Example 1

A compound contains 52.2% carbon (C), 13.0% hydrogen (H), and 34.8% oxygen (O). Work out its empirical formula.

(RAM of C = 12, H = 1 and O = 16)

SOLUTION

Since percentage is usually out 100, then assume you have 100 g of the substance. Then convert the percentage of each element into mass in grams. Thus

Carbon = 52.2 g, H = 13.0 g and 34.8 g.



Element	Mass (g)	Number of moles	Simplest mole ratio
Carbon (C)	52.2	$\frac{52.2}{12} = 4.35$	$\frac{4.35}{2.175} = 2$
Hydrogen (H)	13.0	$\frac{13.0}{1} = 13$	$\frac{13}{2.175} = 6$
Oxygen (O)	34.8	$\frac{34.8}{16} = 2.175$	$\frac{2.175}{2.175} = 1$

The empirical formula of the compound is: **C₂H₆O**

Example 2

A compound was found to contain 3.2 g of copper, 0.6 g of carbon and 2.4 g of oxygen. Find its empirical formula. (RAM of Cu = 64, C = 12 and O = 16)

Solution

Element	Mass (g)	Number of moles	Simplest mole ratio
Copper (Cu)	3.2	$\frac{3.2}{64} = 0.05$	$\frac{0.05}{0.05} = 1$
Carbon (C)	0.6	$\frac{0.6}{12} = 0.05$	$\frac{0.05}{0.05} = 1$
Oxygen (O)	2.4	$\frac{2.4}{16} = 0.15$	$\frac{0.15}{0.05} = 3$

The empirical formula of the compound is: **CuCO₃**

2. MOLECULAR FORMULA

A molecular formula is a formula that shows the exact or actual number of atoms of each element in one molecule of a compound.

CALCULATING MOLECULAR FORMULA



- Identify or work out the empirical formula
- Identify the molar mass of the compound
- Calculate the empirical formula mass
- Find the empirical formula units using the formula:

$$\text{Empirical formula units} = \frac{\text{Molar mass}}{\text{Empirical formula mass}}$$
- Multiply the subscripts in the empirical formula. The result is the required molecular formula.

Example 3

Calculate the molecular formula of a compound if its empirical formula is CH_2O and has a molar mass of 180 g/mol. (RAM of C = 12, H = 1 and O = 16).

Solution

$$\text{Empirical formula} = \text{CH}_2\text{O}$$

$$\begin{aligned} \text{Empirical formula mass} &= (12 \times 1) + (1 \times 2) + (16 \times 1) \\ &= 30 \text{ g/mol} \end{aligned}$$

$$\text{Molar mass of compound} = 180 \text{ g/mol}$$

$$\begin{aligned} \text{Empirical formula units} &= \frac{180 \text{ g/mol}}{30 \text{ g/mol}} \\ &= 6 \end{aligned}$$

$$\begin{aligned} \text{Molecular formula} &= 6(\text{CH}_2\text{O}) \\ &= \text{C}_6\text{H}_{12}\text{O}_6 \end{aligned}$$

CONCENTRATION OF SOLUTIONS

The concentration of a solution refers to the amount of solute dissolved in a specific volume of a solvent.



WAYS OF EXPRESSING CONCENTRATION OF A SOLUTION

There are **three** ways of expressing concentration of a solution:

1. In moles per unit volume

$$\text{Concentration} = \frac{\text{Number of moles of solute}}{\text{Volume of solution}}$$

The units of concentration in this case are mol/dm³, mol/cm³ and mol/litre

2. In mass per unit volume

$$\text{Concentration} = \frac{\text{Mass of solute}}{\text{Volume of solution}}$$

The units of concentration in this case are g/dm³, g/cm³ and g/litre

3. As a percentage

$$\text{Concentration} = \frac{\text{Mass of solute}}{\text{Mass of solution}} \times 100\%$$

CALCULATING CONCENTRATION OF SOLUTIONS

Example 1

Calculate the concentration of a solution containing 4 moles of sodium hydroxide (NaOH) in 2 dm³ of water.

Solution

$$\begin{aligned} \text{Concentration} &= \frac{\text{Number of moles}}{\text{Volume of solution}} \\ &= \frac{4 \text{ moles}}{2 \text{ dm}^3} \\ &= 2 \text{ mol/dm}^3 \end{aligned}$$

Example 2

Calculate the concentration of sodium carbonate (NaCO₃) solution containing 53 g of the salt dissolved in 2 dm³.



Solution

$$\begin{aligned}\text{Number of moles} &= \frac{\text{Mass}}{\text{Molar mass}} \\ &= \frac{53 \text{ g}}{106 \text{ g/mol}} \\ &= 0.5 \text{ mole}\end{aligned}$$

$$\begin{aligned}\text{Concentration} &= \frac{0.5 \text{ mole}}{2 \text{ dm}^3} \\ &= 0.25 \text{ mol/dm}^3\end{aligned}$$

Example 3

12 g of sodium chloride (NaCl) is dissolved in 100g of water. Calculate the concentration of the solution.

Solution

$$\begin{aligned}\text{Mass of solute} &= 12 \text{ g} \\ \text{Mass of solution} &= 12 \text{ g} + 100 \text{ g} \\ &= 112 \text{ g} \\ \text{Concentration} &= \frac{\text{mass of solute}}{\text{mass of solution}} \times 100\% \\ &= \frac{12 \text{ g}}{112 \text{ g}} \times 100\% \\ &= 0.1\% \text{ NaCl}\end{aligned}$$

MOLARITY

Molarity is defined as the number of moles of a solute per unit volume of the solution. The unit of molarity is the mol per cubic decimeter. It is also called the molar, abbreviated (**M**).



$$1 \text{ mol/dm}^3 = 1 \text{ Molar}$$

$$\text{Molarity} = \frac{\text{Number of moles}}{\text{Volume (dm}^3\text{)}}$$

$$\text{But, number of moles} = \frac{\text{mass}}{\text{Molar mass}}$$

$$\text{Then, molarity} = \frac{\text{mass}}{\text{molar mass} \times \text{volume}}$$

PROBLEM SOLVING ON MOLARITY

Example 1

Calculate the molarity of a solution of sodium hydroxide (NaOH), which was made by dissolving 10 g of solid sodium hydroxide in 250 cm³ of water. (RAM of Na = 23, O = 16 and H = 1)

Solution

$$\text{Number of moles} = \frac{\text{mass of NaOH}}{\text{molar mass of NaOH} \times \text{volume}}$$

$$\text{Volume} = \frac{250}{1000} \text{ dm}^3 = 0.25 \text{ dm}^3$$

$$\begin{aligned} \text{Molar mass of NaOH} &= (23 \times 1) + (16 \times 1) + (1 \times 1) \text{ g/mol} \\ &= 40 \text{ g/mol} \end{aligned}$$

$$\begin{aligned} \text{Molarity} &= \frac{10 \text{ g}}{40 \text{ g/mol} \times 0.25 \text{ dm}^3} \\ &= 1 \text{ M} \end{aligned}$$

Example 2



Calculate the mass of potassium hydroxide (KOH), which needs to be used to prepare 500 cm³ of a 2M solution in water. (RAM of K = 39, O =16 and H =1).

Solution

$$\text{Number of moles} = \text{concentration of KOH} \times \text{volume}$$

$$= 2 \text{ mol/dm}^3 \times \frac{500}{1000} \text{ dm}^3$$

$$= 2 \text{ mol/dm}^3 \times 0.5 \text{ dm}^3$$

$$= 1 \text{ mole}$$

$$\text{Mass of KOH} = \text{Number of moles} \times \text{molar mass}$$

$$= 1 \text{ mole} \times [(39 \times 1) + (16 \times 1) + (1 \times 1)] \text{ g/mol}$$

$$= 1 \text{ mole} \times 56 \text{ g/mol}$$

$$= 56 \text{ g}$$

STANDARD SOLUTIONS

A standard solution is a solution whose concentration is known.

METHODS OF PREPARING STANDARD SOLUTIONS

There are two methods of preparing standard solutions; dissolution of solutes and dilution of stock solutions.

1. DISSOLUTION OF SOLID SOLUTES

In this method, a solid solute of a measured mass is dissolved in a solution of a known volume.

To prepare a standard solution by this method, one needs to know:

- the concentration of the solution to be prepared.
- the volume of the solution to be prepared.

STEPS FOR PREPARING STANDARD SOLUTION BY SOLUTE DISSOLUTION



- Calculate the mass of the solute to be dissolved.
The formula used is: mass of solute = molarity \times molar mass \times volume of solution
- Weigh the calculated mass of the solute using a balance.
- Dissolve the solute completely in a beaker.
- Transfer the solution quantitatively into a volumetric flask of the required volume.
- Add water into the volumetric flask up to the mark.
- Put a stopper and shake to mix thoroughly.

NB: Always keep prepared solutions in bottles and label them. Do not keep them in the volumetric flask.

Example

Describe how you would prepare 250 ml of 2M potassium carbonate (K_2CO_3) solution using solid potassium carbonate. (RAM of K = 39, C = 12 and O = 16).

Solution

- Firstly, the mass of potassium carbonate to be dissolved is calculated using the formula:

$$\begin{aligned}
 \text{Mass of } K_2CO_3 &= \text{molarity} \times \text{molar mass} \times \text{volume} \\
 &= 2M \times [(39 \times 2) + (12 \times 1) + (16 \times 3)]g/mol \times 0.25 \text{ dm}^3 \\
 &= 2M \times 138 \text{ g/mol} \times 0.25 \text{ dm}^3 \\
 &= 69 \text{ g}
 \end{aligned}$$

- 69g of solid potassium carbonate is weighed using a balance and placed in a beaker.
- Using distilled water, the solid potassium carbonate is dissolved quantitatively.
- Then, the potassium carbonate solution is transferred into a 250 ml volumetric flask. The beaker is rinsed with distilled water several times, adding the solution into the volumetric flask.
- Distilled water is added into the flasks up to the mark.



- The flask is covered on top and shaken to mix thoroughly. The concentration of the solution will be 2M potassium carbonate.

2. DILUTION OF STOCK SOLUTIONS

Dilution is the process of making a highly concentrated solution less concentrated. The **stock solution** is the concentrated solution that will be diluted before using it. In order to prepare a standard solution by dilution, one needs to know:

- the volume of the solution to be prepared.
- the concentration of the stock solution.
- the concentration of new solution

DILUTION FORMULA

When a solution is diluted, the number of moles of solute in the solution does not change. This means that the number of moles of solute before dilution is equal to the number of moles solute in the solution after dilution.

Since number of moles = concentration \times volume

Letting C_1 = initial concentration

V_1 = initial volume

C_2 = final concentration (concentration of diluted solution)

V_2 = final volume (new volume of solution)

The dilution law is given as:

$$C_1V_1 = C_2V_2$$

STEPS FOR PREPARING STANDARD SOLUTION BY DILUTION

1. Calculate the volume of the stock solution to be transferred.

The formula is given as: $V_1 = \frac{C_2 \times V_2}{C_1}$



2. Measure the calculated volume using a measuring cylinder or pipette.
3. Transfer it into a volumetric flask of the required volume.
4. Rinse the measuring cylinder with distilled water and transfer the water into the volumetric flask.
5. Add water into the flask up to the mark. Put a stopper and shake to mix.

Example 1

60 cm³ of the solution whose concentration is 15 g/cm³ was diluted with distilled water by raising its volume to 80 cm³. Calculate the concentration of the new solution.

SOLUTION

By dilution formula:

$$\begin{aligned}
 C_1V_1 &= C_2V_2 \\
 15 \text{ g/cm}^3 \times 60 \text{ cm}^3 &= C_2 \times 80 \text{ cm}^3 \\
 C_2 &= \frac{15 \text{ g/cm}^3 \times 60 \text{ cm}^3}{80 \text{ cm}^3} \\
 &= 11.25 \text{ g/cm}^3
 \end{aligned}$$

Example 2

Calculate the amount of water that must be added to 5 cm³ of 2M hydrochloric acid to dilute it to 0.1M.

Solution

By dilution formula

$$\begin{aligned}
 C_1V_1 &= C_2V_2 \\
 2\text{M} \times 5 \text{ cm}^3 &= 0.1 \text{ M} \times V_2 \\
 V_2 &= \frac{2\text{M} \times 5 \text{ cm}^3}{0.1\text{M}}
 \end{aligned}$$



$$\begin{aligned}
 &= 100 \text{ cm}^3 \\
 \text{Water added} &= V_2 - V_1 \\
 &= 100 \text{ cm}^3 - 5 \text{ cm}^3 \\
 &= 95 \text{ cm}^3
 \end{aligned}$$

ACID – BASE TITRATION

Titration is the gradual addition of one solution to another until the reaction between them is complete.

FACTS ABOUT ACID – BASE TITRATION

- The ultimate goal of a titration is to determine the concentration of unknown solution. The process of determining the exact concentration (molarity) of a solution is called **standardization**.
- During the titration, one solution (titrant) is titrated against or added to another solution (analyte) until the reaction between the components in the solutions is complete.

TITRANT

This is the solution of a known concentration which is added to another solution to determine the concentration of the unknown solution.

ANAYLTE

It is the solution of unknown concentration.

END POINT

It is the balanced point whereby an acid is completely neutralized by a base. The end point is shown by an indicator.

INDICATOR



An indicator is a dye that has a different colour in acidic or basic solutions. Examples of indicators are used during a titration are phenolphthalein and Methyl orange. When the end point is reached, there is a change in colour of the indicator.

APPARATUS USED IN A TITRATION

- Clamp and clamp stands
- Burette or syringe
- Dropper bottle
- Measuring cylinder
- Funnel
- Conical flask or beaker
- White tile

STEPS TO BE FOLLOWED WHEN CARRYING OUT A TITRATION

1. The apparatus is set up as shown below.

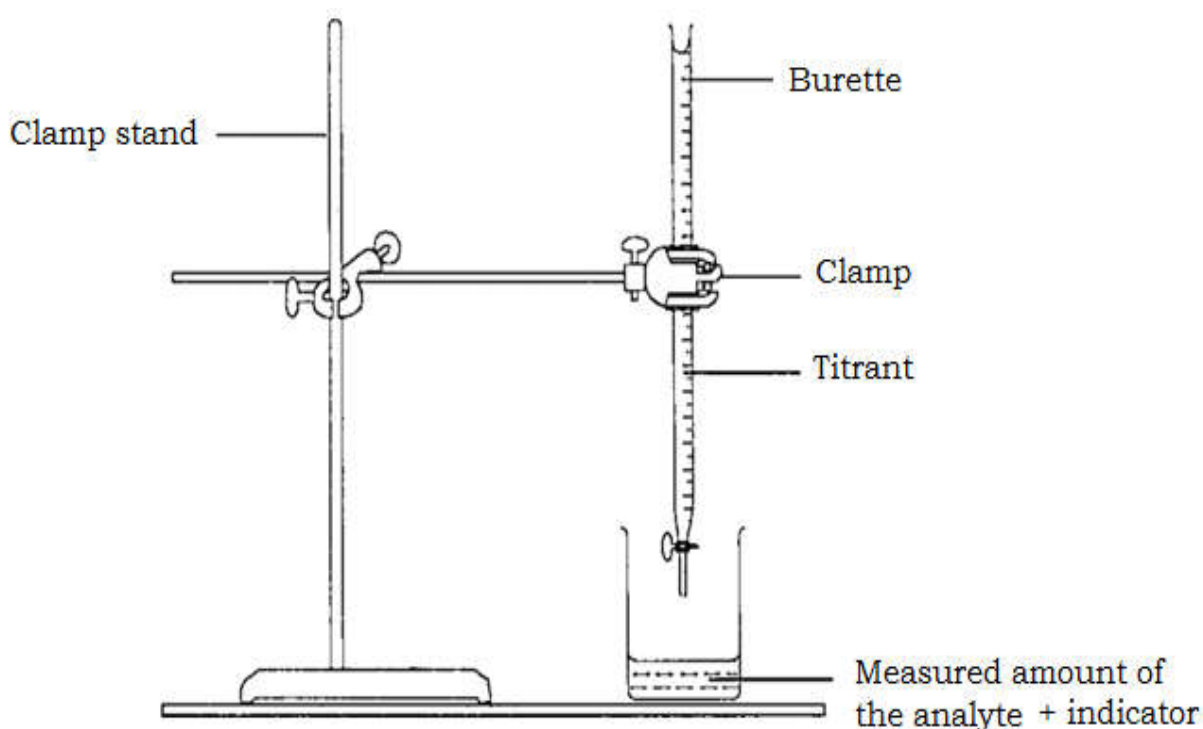

2. The titrant is added into the burette.
3. A specific volume of the solution to be titrated is poured into a conical flask.

4. The indicator is added into the conical flask.
5. The titrant is slowly added to the solution being titrated until there is a colour change.
6. The volume of the titrant added from the burette is recorded.

CALCULATING CONCENTRATION OF UNKNOWN SOLUTION

If the titrant and analyte have a mole ratio of 1:1 in the balanced equation, the concentration of the unknown solution is calculated using the formula:

$$C_a \times V_a = C_b \times V_b$$

where

C_a	=	concentration of the acid used
V_a	=	volume of the acid used (cm^3)
C_b	=	concentration of the alkali used
V_b	=	volume of the alkali used (cm^3)

On the other hand if the titrant and analyte have a mole ratio of greater than 1:1 in the balanced equation (e.g. 2:1), the concentration of the unknown solution is calculated using the formula:

$$\frac{C_a \times V_a}{N_a} = \frac{C_b \times V_b}{N_b}$$

where

N_a	=	number of moles of the acid shown in the chemical equation
N_b	=	number of moles of the alkali shown in the chemical equation

PROBLEM SOLVING ON TITRATION

Example 1

You are provided with a burette, a funnel, a measuring cylinder, a beaker, clamp and clamp stand, 0.1M sulphuric acid (0.1M H_2SO_4), sodium hydroxide solution of unknown concentration, phenolphthalein indicator and a white tile or paper.



a. Set up the apparatus as shown below.

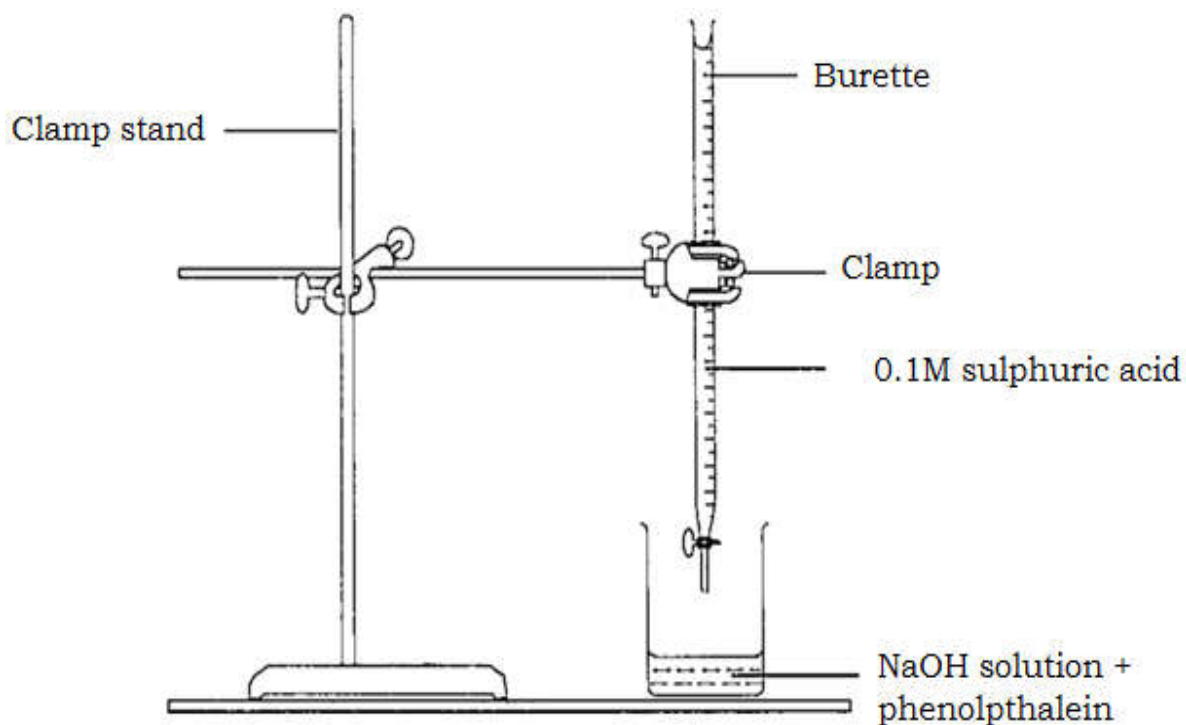

- b. Fill the burette with sulphuric acid (H_2SO_4) up to the zero mark.
- c. Pour 15 cm^3 of sodium hydroxide into a beaker.
- d. Add three drops of phenolphthalein indicator to the sodium hydroxide.
- e. Slowly, add the sulphuric acid from the burette to sodium hydroxide, shaking the beaker all the time, until the pink colour disappears.
- f. Note and record the volume of sulphuric acid used.

Initial volume of sulphuric acid (cm^3)	Final volume of sulphuric acid (cm^3)	Volume of sulphuric acid used (cm^3)

- g. Empty the beaker and rinse it with distilled water.
- h. Repeat steps c to f.
- i. Calculate the average volume of sulphuric acid used.

- j. Write a balanced equation for the reaction.
 k. Calculate the concentration of hydrochloric acid.

Example 2

In a titration, 11.6 cm³ of 3.0M of sulphuric acid (H₂SO₄) was required to neutralize 25 cm³ of sodium hydroxide (NaOH) of unknown concentration.

- a. Identify each of the following in the titration; titrant, analyte

Solution

The titrant is sulphuric acid. The analyte is sodium hydroxide.

- b. Write down a balanced equation for the reaction.

Solution

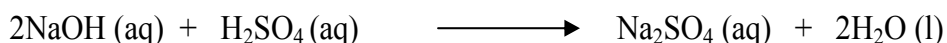

- c. Calculate the concentration of sodium hydroxide.

Solution

The titrant and analyte have a mole ratio of 2:1. Therefore concentration of sulphuric acid is calculated using the formula:

$$\begin{aligned} \frac{C_a \times V_a}{N_a} &= \frac{C_b \times V_b}{N_b} \\ C_b &= \frac{C_a \times V_a}{N_a} \times \frac{N_a}{V_b} \\ &= \frac{3.0\text{M} \times 11.6\text{cm}^3}{1} \times \frac{2}{25\text{cm}^3} \\ &= 2.784\text{M} \end{aligned}$$

The concentration of sodium hydroxide is **2.784M**.

LIMITING AND EXCESS REAGENT

The **limiting reagent** is the reactant that is completely used up in a reaction while the other is still available. The quantity of the limiting reagent controls the amount of product formed by the reaction. The **excess reagent** is the reactant that remains after the chemical reaction has reached equilibrium.



DETERMINING LIMITING AND EXCESS REAGENTS IN A CHEMICAL REACTION

To determine the limiting reagent and the excess reagent in a chemical reaction, there are four important guidelines.

1. Ensure the chemical equation is balanced.
2. Convert given masses into moles.
3. Calculate the number of moles of product produced by each reactant.
4. The reactant that produces the smaller number of moles of product is the limiting reagent.

Example 1

Magnesium reacts with oxygen to form magnesium oxide according to the equation:

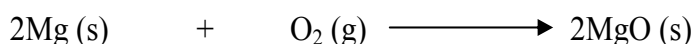

If 6 g of magnesium reacts with 2 g of oxygen determine the:

- a. limiting reagent and excess reagent
- b. mass of magnesium oxide formed. (RAM of Mg = 24 and O = 16)

Solution

$$\begin{aligned} \text{a. Number of moles of magnesium} &= \frac{\text{mass of magnesium}}{\text{molar mass}} \\ &= \frac{6 \text{ g}}{24 \text{ g/mol}} \\ &= 0.25 \text{ mole} \end{aligned}$$

$$\begin{aligned} \text{Number of moles of oxygen} &= \frac{\text{mass of oxygen}}{\text{molar mass}} \\ &= \frac{2 \text{ g}}{32 \text{ g/mol}} \\ &= 0.0625 \text{ mole} \end{aligned}$$

To find the number of moles of product formed by each reactant, we use the balanced equation.

- i. From the balanced equation
$$2 \text{ moles Mg} = 2 \text{ moles MgO}$$



$$0.25 \text{ mole Mg} = 0.25 \text{ mole MgO}$$

ii. From the balanced equation

$$1 \text{ mole O}_2 = 2 \text{ moles MgO}$$

$$0.0625 \text{ mole O}_2 = y$$

$$y = 0.0625 \times 2$$

$$= 0.125 \text{ mole MgO}$$

Comparing the number of moles of product each reactant produces, it can be seen that O₂ gives out the smaller number.

Hence, O₂ is the limiting reagent while Mg is the excess reagent.

b. The quantity of the product formed is controlled by the limiting reagent.

Thus

$$0.0625 \text{ mole of O}_2 = 0.125 \text{ mole of MgO}$$

$$\text{Mass of MgO} = \text{Number of moles} \times \text{molar mass}$$

$$= 0.125 \text{ mole} \times 40 \text{ g/mol}$$

$$= 5 \text{ g}$$

THEORETICAL AND PERCENTAGE YIELD OF A CHEMICAL REACTION

The yield is the amount of product obtained from a chemical reaction. There are two kinds of yield: theoretical and actual.

Theoretical yield is the amount of a product obtained from the balanced equation without doing an experiment while **actual yield** is the amount of a product obtained by experiment.

CALCULATING PERCENTAGE YIELD OF A REACTION

The percentage yield of a chemical reaction is calculated using the formula:



$$\text{Percentage yield} = \frac{\text{Actual yield} \times 100}{\text{Theoretical yield}}$$

Example 1:

2.34 g of aluminium reacts with excess copper (II) sulphate solution to produce 3.89 of copper according to the equation:

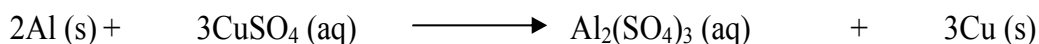

Determine the theoretical, actual and percentage yield of copper.

(RAM of Cu = 64 and Al = 27)

Solution

a. To find the theoretical yield

From the balanced equation

$$2 \text{ moles Al} = 3 \text{ moles Cu}$$

$$2 \times 27\text{g Al} = 3 \times 64\text{g Cu}$$

$$54\text{g Al} = 192\text{g Cu}$$

$$2.34\text{g Al} = y$$

$$y = \frac{2.34 \times 192}{54}$$

$$= 8.32\text{g}$$

The theoretical yield of copper is 8.32g;

b. The actual yield of copper is 3.89g

$$\text{c. Percentage yield} = \frac{\text{Actual yield}}{\text{Theoretical yield}} \times 100$$

$$= \frac{3.89\text{g}}{8.32\text{g}} \times 100$$

$$= 46.75\%$$

CHAPTER 6 : HEATS OF REACTION

TYPES OF REACTIONS IN RELATION TO HEAT CHANGES

There are two types of chemical reactions in relation to heat changes. These are:

- Exothermic reactions
- Endothermic reactions

1. EXOTHERMIC REACTIONS

An exothermic reaction is a chemical reaction that releases heat energy from the system to the surroundings. The surroundings can be the container or the container. When the heat is given out, the reaction mixture and its surroundings get hotter.

Examples of exothermic reactions are:

- Combustion
- Neutralization reactions
- Rusting
- Dehydration of sucrose by sulphuric acid
- Reaction between sodium hydroxide and water

2. ENDOTHERMIC REACTIONS

An endothermic reaction is a chemical reaction that takes in heat energy from the surroundings. When the heat energy is absorbed from the surroundings, the reaction container or vessel feels colder.

Examples of endothermic reactions are:

- Photosynthesis
- Dissolution of salts in water e.g. Ammonium nitrate
- Evaporation of liquid water
- Melting of ice cubes



INVESTIGATING TEMPERATURE CHANGES INVOLVED IN EXOTHERMIC AND ENDOTHERMIC REACTIONS AND PROCESSES

Experiment

Aim

To describe the temperature changes involved in exothermic and endothermic reactions.

Materials

2 test tubes in a rack, a measuring cylinder, thermometer, spatula, tap water, ammonium chloride and sodium hydroxide pellets.

Procedure

1. Pour 5 cm³ of water into each test tube.
2. Measure the initial temperature of water in each test tube and record the results in the appropriate spaces in the table.
3. Add half spatula of ammonium chloride (NH₄Cl) in one test tube and shake gently.
4. Measure the temperature of ammonium chloride solution and record the results in the table.
5. Repeat steps **c** and **d** using sodium hydroxide (NaOH) pellets.

Table of results

Solution	Initial temperature (°C)	Final temperature (°C)	Temperature change (Final temperature – Initial temperature) (°C)
Ammonium chloride (NH ₄ Cl)			
Sodium hydroxide (NaOH)			

6. State whether the change in each case is exothermic or endothermic.

Observations

- a. When ammonium chloride is dissolved in water, the temperature of the solution is lower when compared to the initial temperature of the water. In addition, the test tube felt cold when touched.



- b. When sodium hydroxide is dissolved in water, the temperature of the solution is higher when compared to the initial temperature of the water. In addition, the test tube felt hot when touched.

Interpretation of results

A decrease in temperature means that heat energy was absorbed during the reaction while increase in temperature means that heat energy was released into the surroundings during the reaction. The dissolving of ammonium chloride in water is therefore endothermic while the dissolving of sodium hydroxide in water is exothermic.

Conclusion

In endothermic reactions, temperature decreases while in exothermic reactions, temperature increases.

Let T_i = Initial temperature
 T_f = Final temperature
 ΔT = Change in temperature

In endothermic reactions, ΔT is negative since the final temperature is lower than the initial temperature.

In exothermic reactions, ΔT is positive since the final temperature is greater than the initial temperature.

IDENTIFYING EXOTHERMIC AND ENDOTHERMIC REACTIONS FROM THERMO-CHEMICAL EQUATIONS

A thermo-chemical equation is a balanced equation that includes physical states of all reactants and products and the enthalpy change.

Enthalpy

Enthalpy is the energy stored in the bonds of a substance. It is given the symbol **H** and is measured in kilojoules (kJ).

Enthalpy change

It is the change in energy going from reactants to products. It is shown as ΔH ('delta H'). ΔH is also called the heat of reaction.

For an exothermic reaction, enthalpy change is negative while for an endothermic reaction it is positive.



EXAMPLES OF THERMO-CHEMICAL EQUATIONS

Identify whether each of the following is endothermic or exothermic basing on enthalpy change.



Solution

The reaction is exothermic since enthalpy change has a negative sign.

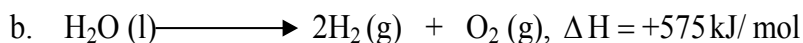

Solution

The reaction is endothermic since enthalpy change has a positive sign.

ENERGY LEVEL DIAGRAMS

An energy level diagram is a graph showing energy changes involving reactants and products during a chemical reaction.

ENERGY LEVEL DIAGRAM FOR EXOTHERMIC REACTIONS

In exothermic reactions, energy level decreases as the reaction proceeds. For this reason, the reactants are shown at a higher level than products on the diagram.

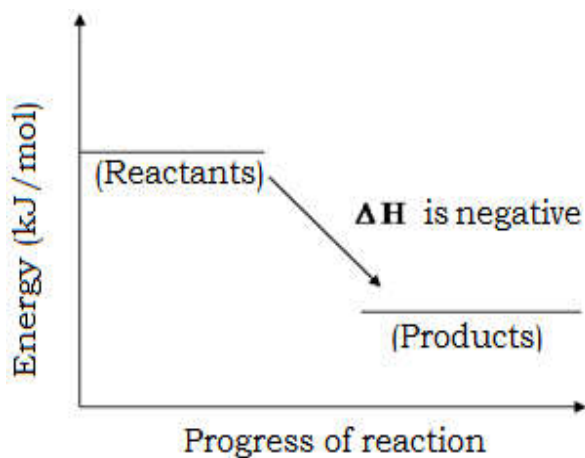

The arrow point points downwards. It shows that heat energy is lost or given out.

ENERGY LEVEL DIAGRAMS FOR ENDOTHERMIC REACTIONS

In endothermic reactions, energy level increases as the reaction proceeds. Therefore, reactants are shown below products in the diagram.

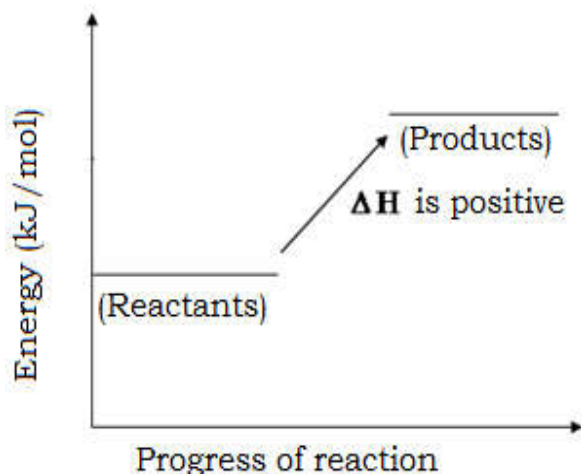

The arrow points upwards. It shows that heat energy is taken in or gained.

WORKED EXAMPLES

Draw energy level diagrams for each of the following reactions:

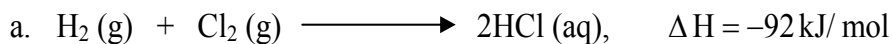

Solution

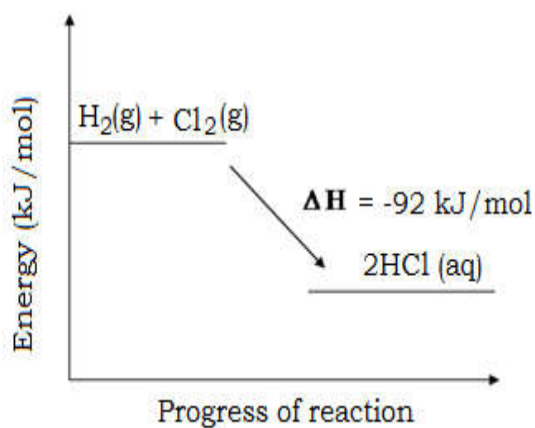

(a)

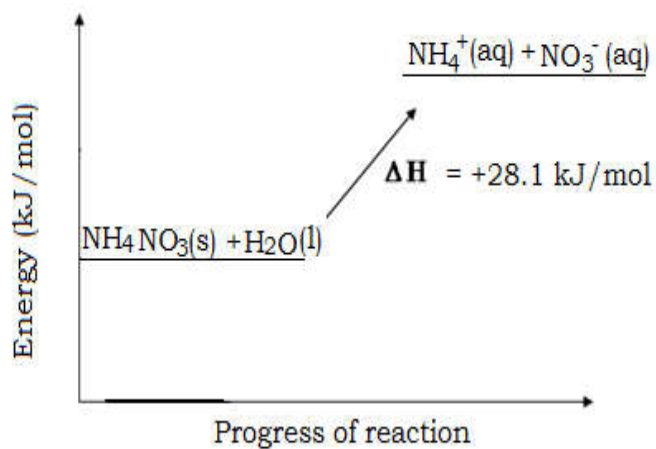

(b)

BOND ENERGIES

Bond energy is the amount of energy required to break one mole of chemical bonds in a molecular element or compound. Different chemical bonds have different bond energies. The unit of bond energy is the kilojoule per mole (kJ/mol). Examples of bond energies are shown below.

Chemical bond	Bond energy (kJ/mol)
H-H	436
O=O	498
O-H	464
C-H	413
C-C	346
Cl-Cl	242
C=O	805

ENERGY CHANGES INVOLVED BOND BREAKING AND BOND FORMATION

During any chemical reaction, old bonds are broken. At the same time, new bonds are formed. To break a bond, requires energy. This energy is needed to separate the atoms or ions against the attractive forces. Therefore, bond breaking is endothermic.

On the other hand, bond formation gives out heat energy. Therefore bond formation is exothermic.

CALCULATING OVERALL ENERGY CHANGES OF REACTIONS USING BOND ENERGIES

The overall energy change is the difference between the energy required to break existing bonds and the energy given off when new bonds are made.

$$\Delta H = \text{energy required to break bonds} - \text{energy given out when bonds are made}$$



Example

Methane burns in excess oxygen to produce carbon dioxide and water according to the equation:

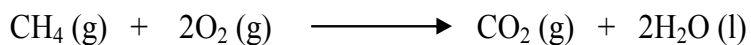

- Calculate the overall enthalpy change for the reaction.
- State whether the reaction is endothermic or exothermic based on enthalpy change.

[Hint: use the bond energies data given in the table above]

Solution

- Breaking 4 C–H bonds in methane requires

$$4 \times 413 \text{ kJ} = 1652 \text{ kJ}$$

Breaking 2 O=O bonds in oxygen requires

$$2 \times 498 \text{ kJ} = 996 \text{ kJ}$$

$$\begin{aligned} \text{Total energy required to break bonds} &= (1652 + 996) \text{ kJ} \\ &= 2648 \text{ kJ} \end{aligned}$$

Making 2 C=O bonds in carbon dioxide gives out

$$2 \times 805 \text{ kJ} = 1610 \text{ kJ}$$

Making 4 O–H bonds in water gives out

$$4 \times 464 \text{ kJ} = 1856 \text{ kJ}$$

$$\begin{aligned} \text{Total energy given out} &= (1610 + 1856) \text{ kJ} \\ &= 3466 \text{ kJ} \end{aligned}$$

$$\text{Overall energy change} = 2648 - 3466$$

$$\Delta H = -818 \text{ kJ}$$

- Basing on enthalpy change the reaction is exothermic.



CHAPTER 6 : ALKANOLS

Alkanols are a family of organic compounds that belong to the class of oxycarbons. They contain oxygen (O), carbon (C) and hydrogen (H) atoms in their compounds. Alkanols are also called **alcohols**.

FUNCTIONAL GROUP OF ALKANOLS

The functional group of Alkanols is **–OH**, the hydroxyl group.

NAMING ALKANOLS

Alkanols are named by replacing the **–e** in the parent alkane having a similar number of carbon atoms with **–anol**.

Number of carbon atoms	Name of alkanol
1	Methanol
2	Ethanol
3	Propanol
4	Butanol
5	Pentanol
6	Hexanol
7	Heptanol
8	Octanol
9	Nonanol
10	Decanol

GENERAL FORMULA OF ALKANOLS

The general formula of alkanols is $C_nH_{2n+1}OH$. The “n” stands for the number of carbon atoms in the molecule. To find the formula of any alkanol given the number of carbon atoms, simply substitute ‘n’ in the general formula, with the value given, and simplify using rules of ordinary algebra.



Example:

Work out the formula of an alkanol with each of the following number of carbon atoms (a) 2 carbon atoms, (b) 4 carbon atoms (c) 10 carbon atoms

SOLUTION

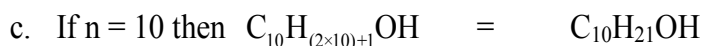
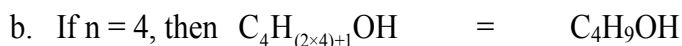
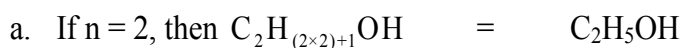

MOLECULAR AND CONDENSED FORMULAE OF ALKANOLS

A **molecular formula** is a formula shows the actual number of atoms of each element in a molecule. For alkanols, the functional group is also shown in the molecular formula.

A **Condensed formula** is a formula which shows how atoms are attached to each other in the structure of the molecule.

The table below shows the molecular and condensed formulae of the first ten alkanols.

Name of alkanol	Molecular formula	Condensed formula
Methanol	CH_3OH	CH_3OH
Ethanol	C_2H_5OH	CH_3CH_2OH
Propanol	C_3H_7OH	$CH_3(CH_2)_2OH$
Butanol	C_4H_9OH	$CH_3(CH_2)_3OH$
Pentanol	$C_5H_{11}OH$	$CH_3(CH_2)_4OH$
Hexanol	$C_6H_{13}OH$	$CH_3(CH_2)_5OH$
Heptanol	$C_7H_{15}OH$	$CH_3(CH_2)_6OH$
Octanol	$C_8H_{17}OH$	$CH_3(CH_2)_7OH$
Nonanol	$C_9H_{19}OH$	$CH_3(CH_2)_8OH$
Decanol	$C_{10}H_{21}OH$	$CH_3(CH_2)_9OH$



STRUCTURAL FORMULAE OF ALKANOLS







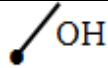

A structural formula is a formula which shows how atoms are bonded to each other in a molecule. The structural formulae of the first ten alkanols are shown below.

Molecular formula	Structural formula
CH ₃ OH	$\begin{array}{c} \text{H} \\ \\ \text{H} - \text{C} - \text{OH} \\ \\ \text{H} \end{array}$
C ₂ H ₅ OH	$\begin{array}{c} \text{H} \quad \text{H} \\ \quad \\ \text{H} - \text{C} - \text{C} - \text{OH} \\ \quad \\ \text{H} \quad \text{H} \end{array}$
C ₃ H ₇ OH	$\begin{array}{c} \text{H} \quad \text{H} \quad \text{H} \\ \quad \quad \\ \text{H} - \text{C} - \text{C} - \text{C} - \text{OH} \\ \quad \quad \\ \text{H} \quad \text{H} \quad \text{H} \end{array}$
C ₄ H ₉ OH	$\begin{array}{c} \text{H} \quad \text{H} \quad \text{H} \quad \text{H} \\ \quad \quad \quad \\ \text{H} - \text{C} - \text{C} - \text{C} - \text{C} - \text{OH} \\ \quad \quad \quad \\ \text{H} \quad \text{H} \quad \text{H} \quad \text{H} \end{array}$
C ₅ H ₁₁ OH	$\begin{array}{c} \text{H} \quad \text{H} \quad \text{H} \quad \text{H} \quad \text{H} \\ \quad \quad \quad \quad \\ \text{H} - \text{C} - \text{C} - \text{C} - \text{C} - \text{C} - \text{OH} \\ \quad \quad \quad \quad \\ \text{H} \quad \text{H} \quad \text{H} \quad \text{H} \quad \text{H} \end{array}$
C ₆ H ₁₃ OH	$\begin{array}{c} \text{H} \quad \text{H} \quad \text{H} \quad \text{H} \quad \text{H} \quad \text{H} \\ \quad \quad \quad \quad \quad \\ \text{H} - \text{C} - \text{C} - \text{C} - \text{C} - \text{C} - \text{C} - \text{OH} \\ \quad \quad \quad \quad \quad \\ \text{H} \quad \text{H} \quad \text{H} \quad \text{H} \quad \text{H} \quad \text{H} \end{array}$
C ₇ H ₁₅ OH	$\begin{array}{c} \text{H} \quad \text{H} \quad \text{H} \quad \text{H} \quad \text{H} \quad \text{H} \quad \text{H} \\ \quad \quad \quad \quad \quad \quad \\ \text{H} - \text{C} - \text{C} - \text{C} - \text{C} - \text{C} - \text{C} - \text{C} - \text{OH} \\ \quad \quad \quad \quad \quad \quad \\ \text{H} \quad \text{H} \quad \text{H} \quad \text{H} \quad \text{H} \quad \text{H} \quad \text{H} \end{array}$
C ₈ H ₁₇ OH	$\begin{array}{c} \text{H} \quad \text{H} \quad \text{H} \quad \text{H} \quad \text{H} \quad \text{H} \quad \text{H} \quad \text{H} \\ \quad \quad \quad \quad \quad \quad \quad \\ \text{H} - \text{C} - \text{C} - \text{C} - \text{C} - \text{C} - \text{C} - \text{C} - \text{C} - \text{OH} \\ \quad \quad \quad \quad \quad \quad \quad \\ \text{H} \quad \text{H} \quad \text{H} \quad \text{H} \quad \text{H} \quad \text{H} \quad \text{H} \quad \text{H} \end{array}$

$C_9H_{19}OH$	$ \begin{array}{ccccccccccc} & H & H & H & H & H & H & H & H & H & \\ & & & & & & & & & & \\ H & - C & - C & - C & - C & - C & - C & - C & - C & - C & - OH \\ & & & & & & & & & & \\ & H & H & H & H & H & H & H & H & H & \end{array} $
$C_{10}H_{21}OH$	$ \begin{array}{cccccccccccc} & H & H & H & H & H & H & H & H & H & H & \\ & & & & & & & & & & & \\ H & - C & - C & - C & - C & - C & - C & - C & - C & - C & - C & - OH \\ & & & & & & & & & & & \\ & H & H & H & H & H & H & H & H & H & H & \end{array} $

SKELLETAL FORMULAE OF ALKANOLS

A skeletal formula is a diagrammatic representation of a molecule in which lines represent bonds between atoms. The lines are drawn in zigzag fashion. Carbon atoms are implied when two bonds meet and no atom listed except for functional groups. The skeletal formulae of the first ten alkanols are shown below.

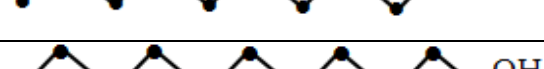
Molecular formula	Skeletal formula
CH_3OH	
C_2H_5OH	
C_3H_7OH	
C_4H_9OH	
$C_5H_{11}OH$	
$C_6H_{13}OH$	
$C_7H_{15}OH$	
$C_8H_{17}OH$	
$C_9H_{19}OH$	
$C_{10}H_{21}OH$	

CLASSIFICATION OF ALKANOLS

Alkanols can be classified as primary, secondary or tertiary. The classification is based on the location of the hydroxyl group.

1. PRIMARY ALKANOL

It is an alkanol in which the hydroxyl group is attached to a carbon atom which is bonded to only one other carbon atom. For example

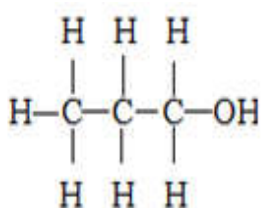

Propan -1- ol

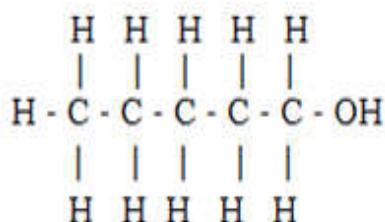

Pentan -1- ol

2. SECODARY ALKANOL

It is an alkanol in which the hydroxyl group is bonded to a carbon atom which is bonded to two other carbon atoms. Examples are shown below

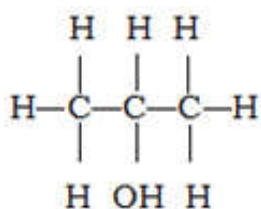

Propan -2- ol

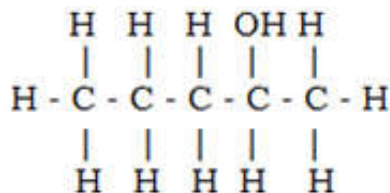

Pentan -2- ol

3. TERTIARY ALKANOL

It is an alkanol in which the hydroxyl group is bonded to a carbon atom which is bonded to other three carbon atoms. An example is shown below.

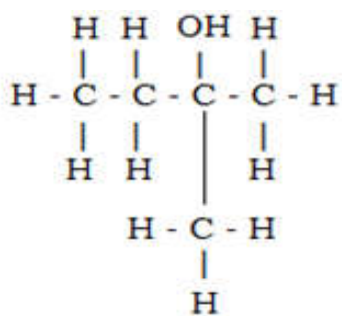

2 - methyl butan -2- ol

PREPARATION OF ETHANOL

Ethanol can be prepared using both indigenous methods and industrial technology.

1. INDIGENOUS METHOD OF PREPARING ETHANOL

The indigenous name for ethanol is kachaso. The process for preparing ethanol using indigenous ways is as follows:

- Maize bran (madeya) is mixed with sugar solution or sugarcane or juices of fruits such as mangoes or masuku.
- The mixture is kept for about 3 – 5 days for fermentation to take place.
- When fermentation is complete, the mixture is distilled in order to obtain ethanol using the apparatus shown below.

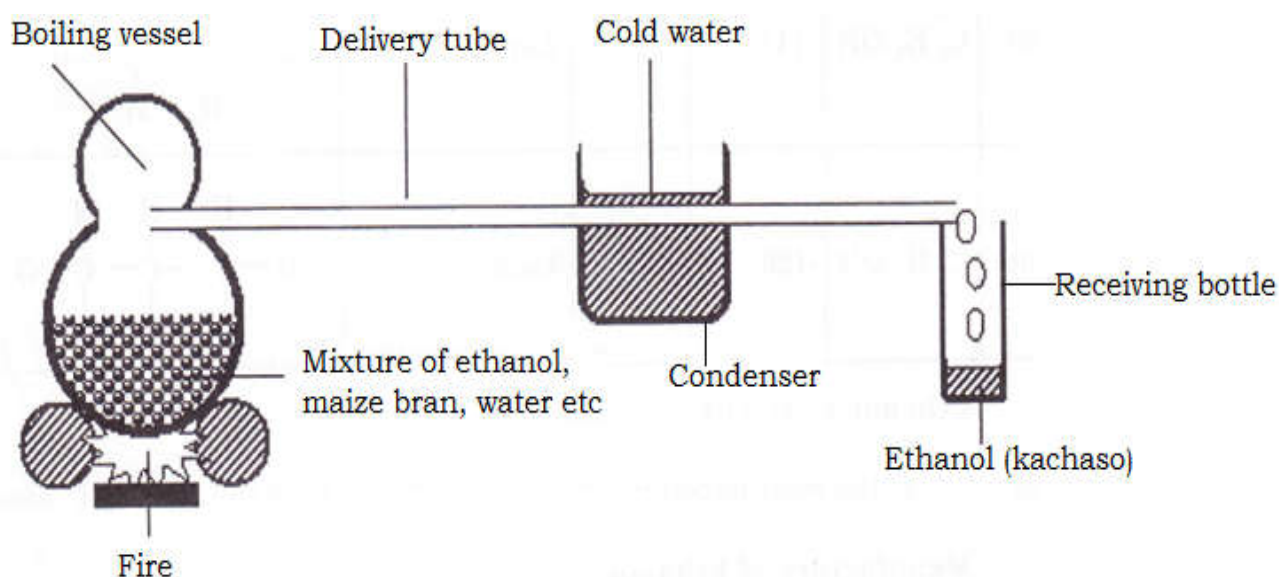

- When the mixture is heated, ethanol boils faster than water because its boiling point is lower.

- The gaseous ethanol rises up in the pot and passes through the delivery tube.
- The cold water in the condenser cools and condenses the gaseous ethanol.
- Liquid ethanol is finally collected in the receiving bottle.

2. INDUSTRIAL METHODS OF PREPARING ETHANOL

In industries, ethanol can be prepared by fermentation of sugars by yeast and by hydration of ethene.

a. PREPARATION OF ETHANOL BY FERMENTATION OF SUGAR BY YEAST

Fermentation is a chemical process whereby sugars are converted to alcohol and carbon dioxide by a catalyst.

- During fermentation of sugars, sugar (glucose) solution is mixed with yeast.
- The mixture is kept at room temperature for about 3 – 4 days in an apparatus shown below.

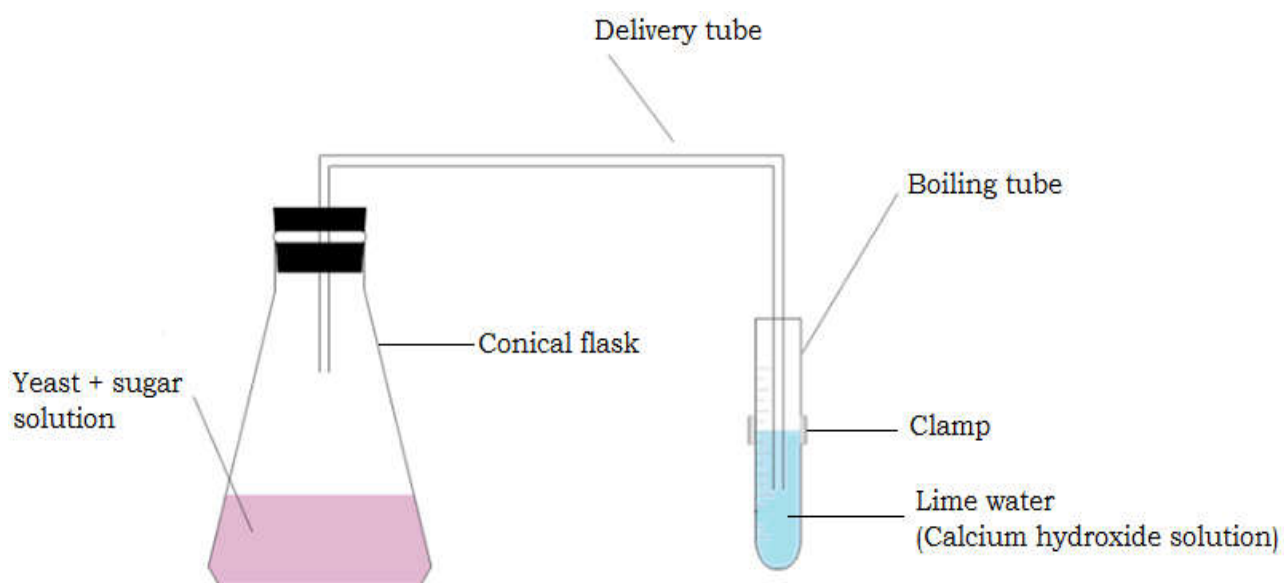

- Yeast contains an enzyme called zymase. This enzyme speeds up the decomposition of sugar into ethanol and water.
- The lime water turns milk, indicating the production of carbon dioxide.

The equation for the reaction is:

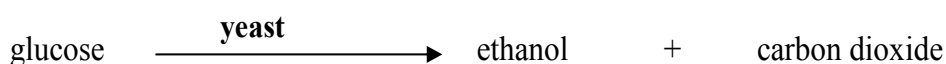

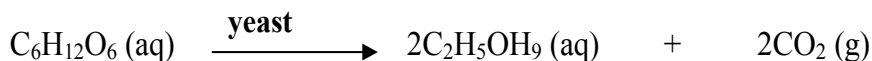

Ethanol produced by this process has of low alcohol content. To obtain a higher percent of ethanol, the mixture separated by fractional distillation.

b. FORMATION OF ETHANOL BY HYDRATION OF ETHENE

Ethanol is prepared by hydrating ethene (reacting it with steam) in the presence of a catalyst such as phosphoric acid (H_3PO_4).



The reaction has two main characteristics:

- It is **exothermic** in nature. Therefore, it carried out at a relatively low temperature of about 300°C .
- It is **reversible**. Ethanol can be dehydrated back into ethene.



PHYSICAL PROPERTIES OF ALKANOLS

1. Alkanols are soluble in water. The solubility of alkanols decreases with an increase in molecular mass. This is so because the proportion of the $-\text{OH}$ group becomes smaller when the size of the molecule gets bigger.
2. The melting and boiling points of alkanols increase as the molecular size increases. This is so because, as the molecular size increases, the intermolecular forces also increase. Hence more energy is needed to overcome.

Alkanols have higher melting and boiling points than hydrocarbons of the same number of carbon atoms. This is because; alkanols form hydrogen bonds between their hydroxyl groups. Hydrogen bonds are stronger than van der Waals's forces in hydrocarbons. More energy is therefore required to break the hydrogen bonds in alkanols.

3. Density of alkanols increases as the molecular mass increases. This is because of the increase in intermolecular forces making them to be very close to each other. This reduces the volume occupied by the molecule hence increasing density.



- The viscosity (resistance to flow) of alkanols increases with an increase in molecular size. This is because the strength of the intermolecular forces increases, making the molecules to stick together.
- Alkanols are volatile liquids. Volatility of alkanols decreases as the molecular size increases. This is because of the increases in the strength of intermolecular forces. Hence more heat is needed to the molecules.

CHEMICAL PROPERTIES/REACTIONS OF ALKANOLS

- Alkanols burn in oxygen to produce carbon dioxide and water. For example,

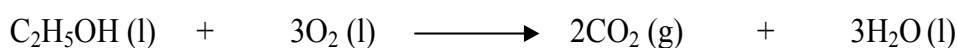

- Alkanols react with alkali metals to form alkanoxides and hydrogen gas. For example

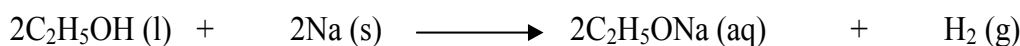
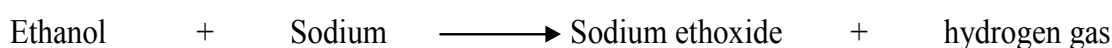

- Alkanols can be oxidized to alkanolic acids. Oxidation is the addition of oxygen to a substance. The oxidation of alkanols can be done in two ways:

- Using oxidizing agents such as acidified potassium dichromate (VI) or acidified potassium permanganate (VII)

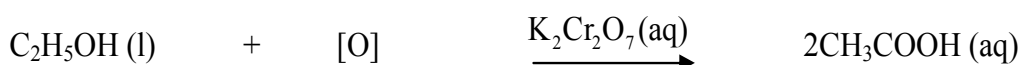
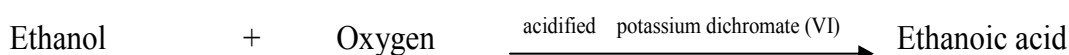

- Oxidation by atmospheric oxygen. For example, if ethanol is exposed to the air can be oxidized to and become Ethanoic acid. An example is wine turning sour if left open to the atmosphere for too long is due to the presence of Ethanoic acid in the wine.

- Alkanols can be dehydrated by concentrated sulphuric acid to produce alkenes. For example:

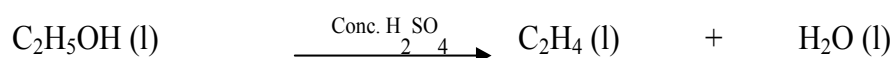

Concentrated sulphuric acid is use as the **dehydrating agent**.



5. Alkanols react with alkanolic acids to form alkanoates (esters) and water. The reaction of alkanolic acids with alkanols to form esters is called **esterification**.

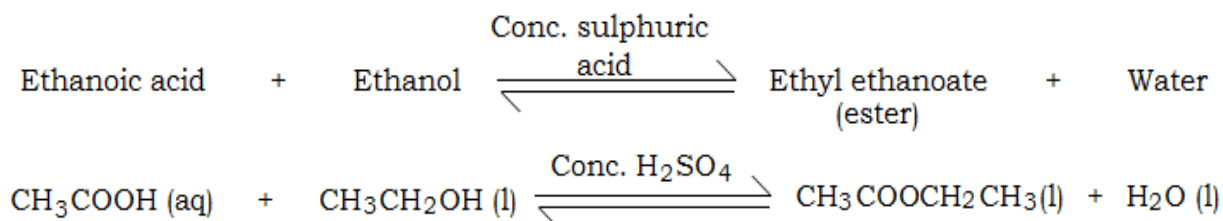

USES OF ETHANOL

1. Used as a solvent.
2. Used in the manufactures of varnishes, ink, glues, and paints.
3. Used as a fuel in cars. It can be blended with gasoline (petrol) or instead of petrol.
4. Used in alcoholic drinks e.g. wines, wines and spirits.
5. Used in the manufactures of deodorants, perfumes because it evaporates easily.
6. Used as an antiseptic in specified concentrations.
7. Moderate consumption of alcohol has numerous health benefits such as greater protection heart diseases, decrease common infections and improvement in factors that influence blood clotting.

DANGERS OF EXCESSIVE CONSUMPTION OF ALCOHOLIC DRINKS

1. Addiction (alcoholism) which can destroy physical and emotional health.
2. Causes of some cancers such as liver cancer, mouth cancer, pharynx cancer, esophagus cancer and pancreatic cancer.
3. Causes cardiac problems such as high blood pressure, heart failure and stroke.
4. Causes miscarriages in pregnant women.
5. Can influence a person to commit suicide or suffer serious injury.
6. Influences a person to indulge in risky sexual behaviours leading to unwanted pregnancies, HIV and AIDS, and other sexually transmitted infections (STIs).
7. Loss of employment leading to poverty.
8. Causes liver cirrhosis.



TOPIC 7 : ALKANALS AND ALKANONES

Alkanals and alkanones are two separate homologous series that belong to the oxycarbonyl class of organic compounds. Alkanals are also called **aldehydes** while alkanones are also called **ketones**.

FUNCTIONAL GROUP OF ALKANALS AND ALKANONES

The functional group of alkanals and alkanones is the same and it is called the carbonyl group, $C=O$.

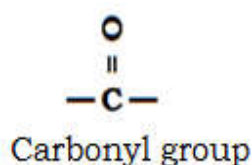

NOMENCLATURE OF ALKANALS

The name of the alkanal is derived from the parent alkane with the same number of carbon atoms. The $-e$ ending from the parent alkane is replaced by $-al$.

Number of carbon atoms	Name of alkanal
1	Methanal
2	Ethanal
3	Propanal
4	Butanal
5	Pentanal

GENERAL FORMULA OF ALKANALS

The general formula of alkanals is $C_nH_{2n+1}CHO$. This formula can be used to work the formula of any alkanal given the value of n .

Example: Work out the formula of the alkanal given the following values of n .

a. $n = 0$



b. $n = 1$

c. $n = 4$

Solution:

a. If $n = 0$, $H_{(2 \times 0) + 1}CHO = HCHO$

b. If $n = 1$, $C_1H_{(2 \times 1)}CHO = CH_3CHO$

c. If $n = 4$, $C_4H_{(2 \times 4) + 1}CHO = C_4H_9CHO$

MOLECULAR AND CONDENSED FORMULAE OF ALKANALS

The table below shows the molecular and condensed formulae of the first five alkanals.

Name of alkanal	Molecular formula
Methanal	HCHO
Ethanal	CH ₃ CHO
Propanal	C ₂ H ₅ CHO
Butanal	C ₃ H ₇ CHO
Pentanal	C ₄ H ₉ CHO

STRUCTURAL FORMULA OF ALKANALS

In alkanals, at least one hydrogen atom is bonded to the carbonyl group. The other group is an alkyl group. The general structure of alkanals is shown below.



Where **R** represents an alkyl group such as CH₃ –, CH₃CH₂ –, CH₃CH₂CH₂ – etc, except in methanal.

The structures of the first five alkanals are shown in the table below.



Name of alkanal	Structure of alkanal
Methanal	$\begin{array}{c} \text{O} \\ \\ \text{H} - \text{C} - \text{H} \\ \\ \text{H} \end{array}$
Ethanal	$\begin{array}{c} \text{H} \quad \text{O} \\ \quad \\ \text{H} - \text{C} - \text{C} - \text{H} \\ \\ \text{H} \end{array}$
Propanal	$\begin{array}{c} \text{H} \quad \text{H} \quad \text{O} \\ \quad \quad \\ \text{H} - \text{C} - \text{C} - \text{C} - \text{H} \\ \quad \\ \text{H} \quad \text{H} \end{array}$
Butanal	$\begin{array}{c} \text{H} \quad \text{H} \quad \text{H} \quad \text{O} \\ \quad \quad \quad \\ \text{H} - \text{C} - \text{C} - \text{C} - \text{C} - \text{H} \\ \quad \quad \\ \text{H} \quad \text{H} \quad \text{H} \end{array}$
Pentanal	$\begin{array}{c} \text{H} \quad \text{H} \quad \text{H} \quad \text{H} \quad \text{O} \\ \quad \quad \quad \quad \\ \text{H} - \text{C} - \text{C} - \text{C} - \text{C} - \text{C} - \text{H} \\ \quad \quad \quad \\ \text{H} \quad \text{H} \quad \text{H} \quad \text{H} \end{array}$

NOMENCLATURE OF ALKANONES

Alkanones take their name from the parent alkane with similar number of carbon atoms. The ending –e is removed and replaced with –one. The smallest alkanone is propanone.

Number of carbon atoms	Name of alkanone
3	Propanone
4	Butanone
5	Pentanone
6	Hexanone
7	Heptanone

GENERAL FORMULA OF ALKANONES

The general formula of alkanones is $C_nH_{2n}O$. The formula can be used to work out the molecular formula of an alkanone given the value of n . The molecular formulae of the first five alkanones are shown in the table below.

Name of alkanone	Molecular formula
Propanone	C_3H_6O
Butanone	C_4H_8O
Pentanone	$C_5H_{10}O$
Hexanone	$C_6H_{12}O$
Heptanone	$C_7H_{14}O$

STRUCTURES OF ALKANONES

In alkanones, the carbonyl group is bonded to two alkyl groups which may be similar or different.

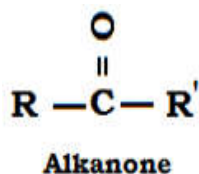

Where **R** and **R'** represent the alkyl groups.

Name of alkanone	Structure of alkanone
Propanone	$ \begin{array}{ccccccc} & \text{H} & \text{O} & \text{H} & & & \\ & & & & & & \\ \text{H} & - \text{C} & - \text{C} & - \text{C} & - \text{H} & & \\ & & & & & & \\ & \text{H} & & \text{H} & & & \end{array} $
Butanone	$ \begin{array}{ccccccc} & \text{H} & \text{H} & \text{O} & \text{H} & & \\ & & & & & & \\ \text{H} & - \text{C} & - \text{C} & - \text{C} & - \text{C} & - \text{H} & \\ & & & & & & \\ & \text{H} & \text{H} & & \text{H} & & \end{array} $

Pentan-2-one or 2-Pentanone	$ \begin{array}{cccccc} & \text{H} & \text{H} & \text{H} & \text{O} & \text{H} \\ & & & & & \\ \text{H} & - \text{C} & - \text{C} & - \text{C} & - \text{C} & - \text{C} - \text{H} \\ & & & & & \\ & \text{H} & \text{H} & \text{H} & & \text{H} \end{array} $
Hexan-2-one or 2-Hexanone	$ \begin{array}{ccccccc} & \text{H} & \text{H} & \text{H} & \text{H} & \text{O} & \text{H} \\ & & & & & & \\ \text{H} & - \text{C} & - \text{C} & - \text{C} & - \text{C} & - \text{C} & - \text{C} - \text{H} \\ & & & & & & \\ & \text{H} & \text{H} & \text{H} & \text{H} & & \text{H} \end{array} $
Heptan-2-one or 2-Heptanone	$ \begin{array}{ccccccc} & \text{H} & \text{H} & \text{H} & \text{H} & \text{H} & \text{O} & \text{H} \\ & & & & & & & \\ \text{H} & - \text{C} & - \text{C} & - \text{C} & - \text{C} & - \text{C} & - \text{C} & - \text{C} - \text{H} \\ & & & & & & & \\ & \text{H} & \text{H} & \text{H} & \text{H} & \text{H} & & \text{H} \end{array} $

SOURCES OF ALKANALS AND ALKANONES

Oxidation of alkanols is the primary source of alkanals and alkanones. The oxidizing agents include acidified potassium permanganate (VII) or acidified potassium dichromate (VI)

a. OXIDATION OF PRIMARY ALKANOLS

Alkanals are produced by oxidation of primary alkanols. For example:

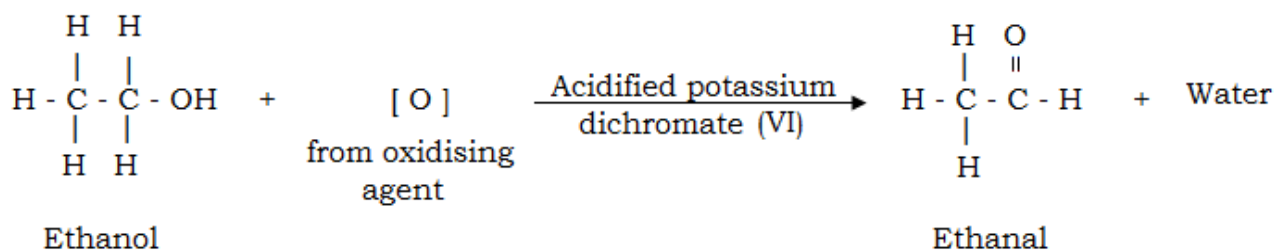

b. OXIDATION OF SECONDARY ALKANOLS

Alkanones are produced by the oxidation of secondary alkanols. For example:

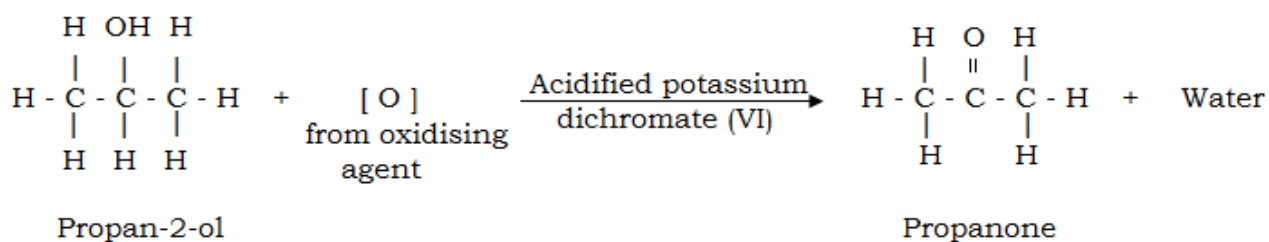

PHYSICAL PROPERTIES OF ALKANALS

- All alkanals are liquids except methanal which is a gas.
- They are colourless and they have a characteristic smell.
- The solubility of alkanals in water decreases moving along the homologous series. Smaller alkanals are more soluble than larger alkanals.
- The melting and boiling points of alkanals increases with an increase in relative molecular mass.

CHEMICAL PROPERTIES OF ALKANALS

- They burn in air to form carbon dioxide and water.
e.g. $2\text{CH}_3\text{CHO}(\text{l}) + 5\text{O}_2(\text{g}) \longrightarrow 4\text{CO}_2(\text{g}) + 4\text{H}_2\text{O}(\text{l})$
- They are easily oxidized to alkanonic acids.
- They can be reduced to primary alkanols. Reduction is the addition of hydrogen to a substance.
- They are neutral to litmus paper.
- They undergo addition polymerizations.

PHYSICAL PROPERTIES OF ALKANONES

- All alkanones are liquids.
- They are polar because of the carbonyl group.
- Their solubility in water decreases moving along the homologous series.
- Their melting and boiling points increase with increasing molecular mass.

CHEMICAL PROPERTIES OF ALKANONES

- They burn in air to form carbon dioxide and water.
- They are not easily oxidized due to the absence of hydrogen on the carbonyl group.
- They are neutral to litmus paper.
- They can be reduced to secondary alkanols.

DISTINGUISHING ALKANALS AND ALKANONES USING CHEMICAL TESTS



Three main tests are carried out to help identify whether a given unknown substance is an alkanal or alkanone. The tests are the Fehling's test, the Brady's test and the Tollen's test (silver mirror test).

a. The Fehling's test

Fehling's test is used to confirm the fact that alkanals are easily oxidized to alkanonic acids.

Procedure

To 15 drops of Fehling's solution in a clean test tube, add about 15 drops of the test liquid. Heat the contents of the tube gently for about 5 minutes.

Result

- If the blue Fehling's solution turns to a red precipitate, then the test substance is either an alkanal or a sugar.
- If the blue colour of Fehling's solution does not disappear, then the test liquid is an alkanone.

b. The Brady's test

The Brady's test is used to detect the presence of the carbonyl group, -C=O , in a compound. The test uses a reagent called 2,4 Dinitrophenylhydrazine (2,4 -DNPH), which is yellow in colour.

Procedure

- Add 2 cm^3 of the test liquid to 2 cm^3 of 2,4 DNPH reagent. Shake well.

Result

If an orange precipitate forms, then the added liquid could be either be an alkanal or an alkanone. This is so because both alkanals and alkanones contain the carbonyl group as their functional group.

c. The Tollen's test

The Tollen's reagent is a mixture of excess ammonia solution and silver nitrate solution. The Tollen's reagent oxidizes an alkanal to alkanonic acid while the silver ions present in the reagent are reduced to silver atoms, forming a silver mirror on the inside of the test tube.



Procedure

- To 3 cm³ of Tollen's reagent, add 2-3 drops of the test liquid.

Result

- If a silver mirror forms inside the test tube, the unknown liquid is an alkanal.
- If a silver mirror does not form, then the test liquid is an alkanone.



TOPIC 8 : ALKANOIC ACIDS

Alkanoic acids are also called carboxylic acids.

FUNCTIONAL GROUP OF ALKANOIC ACIDS

The functional group of alkanoic acids is the carboxyl group and it is represented as -COOH .

NOMENCLATURE OF ALKANOIC ACIDS

To name an alkanoic acid, the -e from the parent alkane is replaced by -oic acid . The table below shows the names of the first ten alkanoic acids.

Number of carbon atoms	Name of alkanoic acid
1	Methanoic acid
2	Ethanoic acid
3	Propanoic acid
4	Butanoic acid
5	Pentanoic acid
6	Hexanoic acid
7	Heptanoic acid
8	Octanoic acid
9	Nonanoic acid
10	Decanoic acid

GENERAL FORMULA OF ALKANOIC ACIDS

The general formula of alkanoic acids is $\text{C}_n\text{H}_{2n+1}\text{COOH}$.

Example

What is the molecular formula of an alkanoic acid when $n = 6$?

Solution: If $n = 6$ then $\text{C}_6\text{H}_{(2 \times 6) + 1}\text{COOH} = \text{C}_6\text{H}_{13}\text{COOH}$.



MOLECULAR AND CONDENSED FORMULAE OF ALKANOIC ACIDS

The table below shows the molecular and condensed formulae of the first ten alkanolic acids.

Name of alkanolic acid	Molecular formula	Condensed formula
Methanoic acid	HCOOH	HCOOH
Ethanoic acid	CH ₃ COOH	CH ₃ COOH
Propanoic acid	C ₂ H ₅ COOH	CH ₃ CH ₂ COOH
Butanoic acid	C ₃ H ₇ COOH	CH ₃ (CH ₂) ₂ COOH
Pentanoic acid	C ₄ H ₉ COOH	CH ₃ (CH ₂) ₃ COOH
Hexanoic acid	C ₅ H ₁₁ COOH	CH ₃ (CH ₂) ₄ COOH
Heptanoic acid	C ₆ H ₁₃ COOH	CH ₃ (CH ₂) ₅ COOH
Octanoic acid	C ₇ H ₁₅ COOH	CH ₃ (CH ₂) ₆ COOH
Nonaic acid	C ₈ H ₁₇ COOH	CH ₃ (CH ₂) ₇ COOH
Decanoic acid	C ₉ H ₁₉ COOH	CH ₃ (CH ₂) ₈ COOH

STRUCTURAL FORMULAE OF ALKANOIC ACIDS

The table shows the structures of the first ten alkanolic acids.







Molecular formula	Structural formula
HCOOH	$\begin{array}{c} \text{O} \\ \\ \text{H} - \text{C} - \text{OH} \end{array}$
CH ₃ COOH	$\begin{array}{c} \text{H} \quad \text{O} \\ \quad \\ \text{H} - \text{C} - \text{C} - \text{OH} \\ \\ \text{H} \end{array}$
C ₂ H ₅ COOH	$\begin{array}{c} \text{H} \quad \text{H} \quad \text{O} \\ \quad \quad \\ \text{H} - \text{C} - \text{C} - \text{C} - \text{OH} \\ \quad \\ \text{H} \quad \text{H} \end{array}$

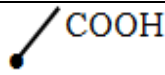
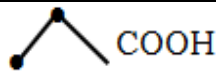

C_3H_7COOH	$ \begin{array}{cccc} H & H & H & O \\ & & & \\ H - C & - C & - C & - C - OH \\ & & & \\ H & H & H & \end{array} $
C_4H_9COOH	$ \begin{array}{ccccc} H & H & H & H & O \\ & & & & \\ H - C & - C & - C & - C & - C - OH \\ & & & & \\ H & H & H & H & \end{array} $
$C_5H_{11}COOH$	$ \begin{array}{cccccc} H & H & H & H & H & O \\ & & & & & \\ H - C & - C & - C & - C & - C & - C - OH \\ & & & & & \\ H & H & H & H & H & \end{array} $
$C_6H_{13}COOH$	$ \begin{array}{ccccccc} H & H & H & H & H & H & O \\ & & & & & & \\ H - C & - C & - C & - C & - C & - C & - C - OH \\ & & & & & & \\ H & H & H & H & H & H & \end{array} $
$C_7H_{15}COOH$	$ \begin{array}{cccccccc} H & H & H & H & H & H & H & O \\ & & & & & & & \\ H - C & - C & - C & - C & - C & - C & - C & - C - OH \\ & & & & & & & \\ H & H & H & H & H & H & H & \end{array} $
$C_8H_{17}COOH$	$ \begin{array}{ccccccccc} H & H & H & H & H & H & H & H & O \\ & & & & & & & & \\ H - C & - C & - C & - C & - C & - C & - C & - C & - C - OH \\ & & & & & & & & \\ H & H & H & H & H & H & H & H & \end{array} $
$C_9H_{19}COOH$	$ \begin{array}{cccccccccc} H & H & H & H & H & H & H & H & H & O \\ & & & & & & & & & \\ H - C & - C & - C & - C & - C & - C & - C & - C & - C & - C - OH \\ & & & & & & & & & \\ H & H & H & H & H & H & H & H & H & \end{array} $

SKELETAL FORMULAE OF ALKANOIC ACIDS

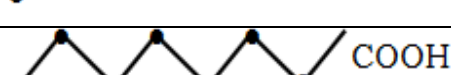
Name of alkanolic acid	Condensed formula	Skeletal formula
Methanoic acid	HCOOH	HCOOH

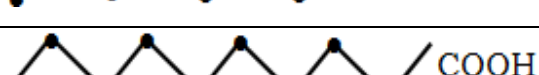
Ethanoic acid	CH_3COOH	
Propanoic acid	$\text{CH}_3\text{CH}_2\text{COOH}$	
Butanoic acid	$\text{CH}_3(\text{CH}_2)_2\text{COOH}$	
Pentanoic acid	$\text{CH}_3(\text{CH}_2)_3\text{COOH}$	
Hexanoic acid	$\text{CH}_3(\text{CH}_2)_4\text{COOH}$	
Heptanoic acid	$\text{CH}_3(\text{CH}_2)_5\text{COOH}$	
Octanoic acid	$\text{CH}_3(\text{CH}_2)_6\text{COOH}$	
Nonaic acid	$\text{CH}_3(\text{CH}_2)_7\text{COOH}$	
Decanoic acid	$\text{CH}_3(\text{CH}_2)_8\text{COOH}$	

NATURAL SOURCES OF ALKANOIC ACIDS

Some of the natural sources of alkanolic acids are:

- Citrus fruits (oranges, lemons) e.g. citric acid.
- Sour milk e.g. lactic acid.
- Vinegar e.g. acetic acid/ethanoic acid.
- Ant, bee and nettle stings e.g. methanoic acid.
- Human sweat e.g. butanoic acid.

PREPARATION OF ALKANOIC ACIDS

Alkanolic acids can be prepared by the oxidation of corresponding alkanols. The oxidising agents are acidified potassium permanganate (VII) or acidified potassium dichromate (VI).

The oxidation is done in two steps:

- First, the alkanol is oxidized to an alkanal. For example

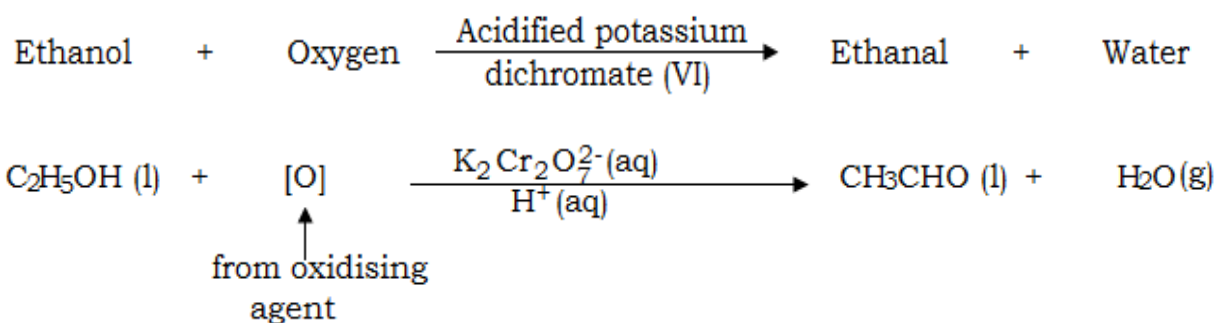

b. Then, the alkanal is further oxidized to an alkanolic acid.

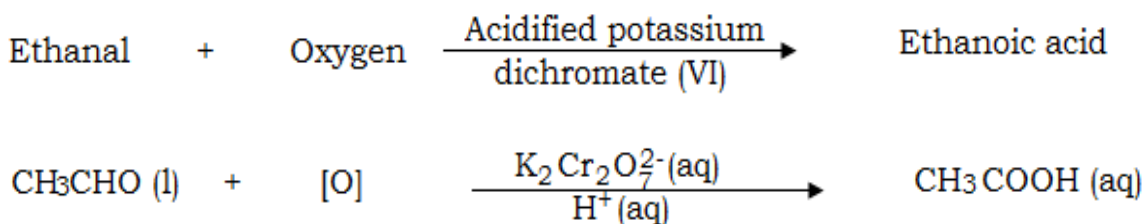

PHYSICAL PROPERTIES OF ALKANOIC ACIDS

- They are liquids at room temperature.
- Smaller alkanolic acids are soluble in water; the larger ones are insoluble in water. Solubility of alkanolic acids in water decrease moving along the series due to an increasing proportion of the hydrocarbon part of the molecule.
- The melting points and boiling points of alkanolic acids increase with the increase in molecular size. There are two reasons for this:
 - As the size of the molecule gets bigger, the van der Waal's forces are increased.
 - There is formation of hydrogen bonds between alkanolic acid molecules because the –OH group of the carboxyl group is more polarized due to the presence of an electron withdrawing group, –C=O.
- Viscosity of alkanolic acids increases with an increase in molecular mass. This is due to increasing stronger and more hydrogen bonds in the acid molecules.

CHEMICAL PROPERTIES OF ALKANOIC ACIDS

- They react with metals to form salts and hydrogen.

Example:

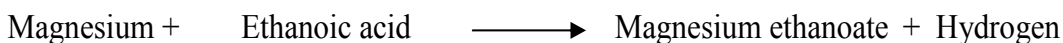

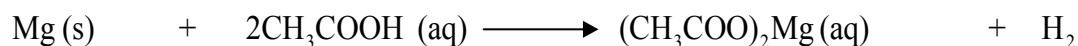

- They react with alkalis to produce salt and water. This reaction is called **neutralization reaction**.

Example:

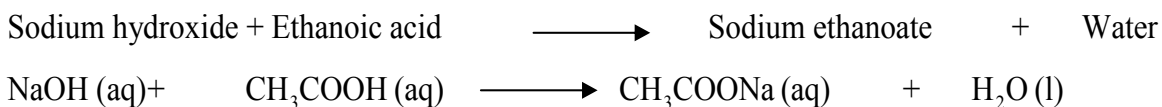

- They react with carbonates to form salts, carbon dioxide and water.

Example:

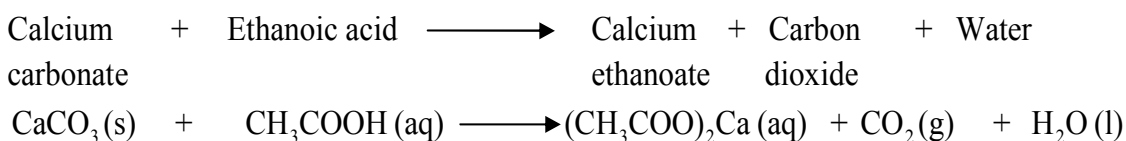

- They react with alkanols to produce alkanoates (esters). This reaction is called **esterification**.

Example:

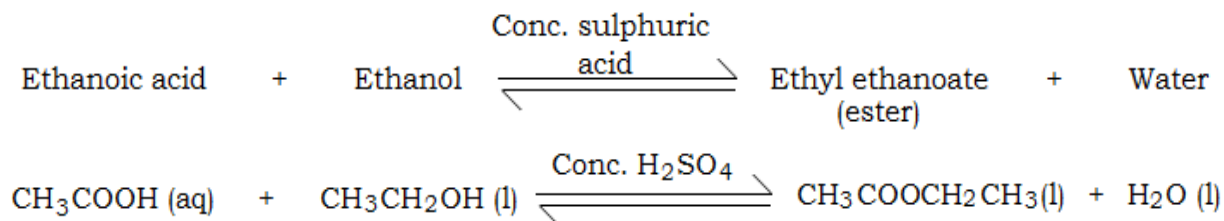

EFFECT OF ALKANOIC ACIDS ON ACID–BASE INDICATORS

Alkanoic acids show acidic behaviours by affecting acid–base indicators:

- They turn blue litmus paper red.
- They have pH values of less than 7.
- They are colourless in phenolphthalein.

ELECTRICAL CONDUCTIVITY OF ALKANOIC ACIDS

Alkanoic acids conduct electricity when in aqueous state. This is because, when dissolved in water, they ionize. The ions enable the alkanoic acid to conduct electricity.

For example, the ionization of ethanoic acid is shown according to the equation:

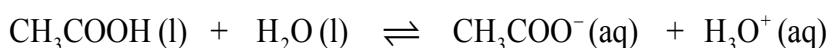

USES OF ALKANOIC ACIDS

- Used as food preservatives e.g. ethanoic acid
- Used as solvents e.g. ethanoic acid
- Used in the production of esters.
- Used in manufacture of medicines such as aspirin.



TOPIC 9 : ALKANOATES

Alkanoates are organic compounds which are formed when alkanolic acids and alkanols react in the presence of a catalyst. They are also called **esters**.

FUNCTIONAL GROUP OF ALKANOATES

The functional group of alkanoates is given as **–COO–**

NOMENCLATURE OF ALKANOATES

The name of an alkanoate has two parts: the acid part and the alkanol part.

- The alkyl part of the alkanol comes first.
- The acid part comes second but the **–oic** ending is replaced by **–oate**.

Example

Work out the names of alkanoates formed when the following substances react:

- Ethanoic acid and methanol
- Butanoic acid and ethanol

Solution:

- The alkyl part of methanol is “methyl”. The acid part ethanoic changes to ethanoate.
The name of the alkanoate is **methyl ethanoate**.
- The alkyl part of ethanol is “ethyl”. The acid part butanoic changes to butanoate.
The name of the alkanoate is **ethyl butanoate**

DRAWING STRUCTURES OF ALKANOATES FORMED FROM GIVEN ALKANOIC ACID AND ALKANOL

To draw structures of alkanoates formed from given alkanolic acid and alkanol, use the following simple steps.

- Write down the structures of the alkanolic acid and the alkanol separately.



- Take away the ending –H from the acid and the –OH from the alkanol. The result is an alkanoate and an alky part respectively.
- Combine the two structures, starting with the acid part and then the alkanol part.

Example:

Draw and name the structure of the alkanoate that will be formed when:

- Methanol reacts with methanoic acid.
- Propanol reacts with Propanoic acid.

Solution:

- The structures of methanol and methanoic acid are:

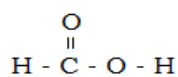

Methanoic acid

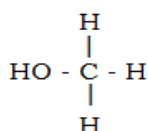

Methanol

Taking away the ending –H from methanoic acid and –OH from methanol we get:

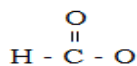

Methanoate

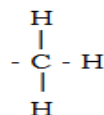

Methyl

Combining the methanoate structure and the methyl structure, we get:

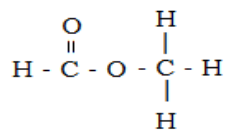

Methyl methanoate

- The structures of propanol and propanoic acid are:

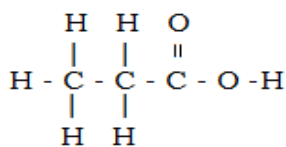

Propanoic acid

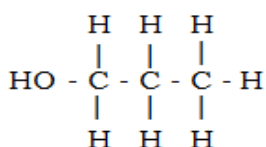

Propanol

The structure of the alkanoate formed is shown as:

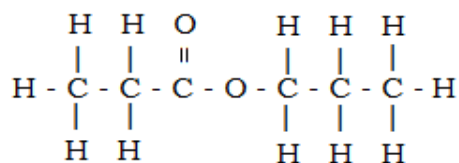

Propyl proanoate

DEDUCING THE REACTANTS OF ESTERIFICATION GIVEN THE STRUCTURE OF THE PRODUCT OF THE REACTION

Example

Deduce the names of the reactants of esterification given each of the following structures of products:

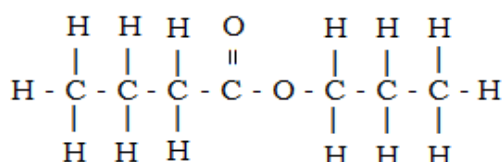

(a)

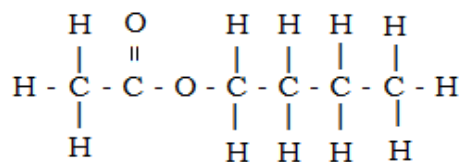

(b)

Solution:

- The alkanoate part contains 4 carbon atoms. The reacting alkanolic acid was butanoic acid. The alkyl part contains 3 carbon atoms. This means the reacting alkanol was propanol. The reactants of this reaction were: **butanoic acid** and **propanol**
- The alkanoate apart has 2 carbon atoms. The reacting acid was ethanoic acid. The alkyl part contains 4 carbon atoms. The reacting alkanol was butanol. Hence the reactants of this reaction were: **ethanoic acid** and **butanol**.

SOURCES OF ALKANOATES

- Natural sources which include:
 - Fruits and flowers
 - Fats and oils
- Alkanoates can be prepared synthetically by condensation reaction of alkanolic acids.

PROPERTIES OF ALKANOATES

- a. They have pleasant fruits smells.

For example

Alkanoate	Fruit smell
Ethyl butanoate	Pineapple
Pentyl ethanoate	Banana

- b. They are volatile liquids.
- c. Small chain alkanoates are fairly soluble in water. Their solubility decreases with increasing chain length.
- d. They have lower melting and boiling points than the alkanoic acids and alkanols of similar molecular mass. This is because alkanoates have no free –OH groups so they do not form hydrogen bonds.
- e. They react with sodium hydroxide in the presence of water (i.e. they are hydrolysed) to produce soap. This reaction is called **saponification**.

To make soap, a fat (natural ester) is boiled with a strong alkaline solution such as sodium hydroxide (NaOH). It is hydrolysed to give glycerol and soap (sodium octadecanoate).

The equation for the reaction is:

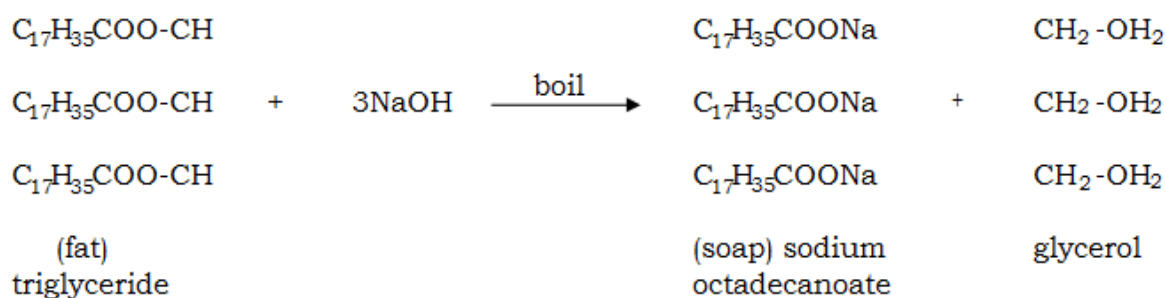

USES OF ALKANOATES

- Used for flavouring e.g. flavours in sweets and biscuits.
- Used as fragrances in perfumes.
- Used as solvents in glues since they evaporate easily.



TOPIC 10: IDENTIFICATION OF UNKNOWN COMPOUNDS

1. DEDUCING FAMILIES AND FORMULAE OF UNKNOWN ORGANIC COMPOUNDS

The families and formulae of unknown organic compound can be deduced given relevant information such as structural formulae, general formulae, and products of chemical reactions, physical and chemical properties.

Example

An organic compound was found to contain 64.8% carbon, 13.6% hydrogen and 21.6% oxygen by mass.

- Calculate the empirical formula of the compound.
- Deduce the family to which the compound could belong.

(RAM of C = 12, H = 1 and O = 16)

Solution

- The empirical formula of the compound is calculated as follows:

Element	Mass (g)	Number of moles	Simplest mole ratio
Carbon (C)	64.8	$\frac{64.8}{12} = 5.4$	$\frac{5.4}{1.35} = 4$
Hydrogen (H)	13.6	$\frac{13.6}{1} = 13.6$	$\frac{13.6}{1.35} = 10$
Oxygen (O)	21.6	$\frac{21.6}{16} = 1.35$	$\frac{1.35}{1.35} = 1$

The empirical formula is $C_4H_{10}O$

- The empirical formula can be worked out exactly using the general formula of alkanols, which is $C_nH_{2n+1}OH$. For example $C_4H_{10}O$ can be written as C_4H_9OH .



Therefore the compound could be an alkanol.

2. DISTINGUISHING ORGANIC COMPOUNDS BASING ON PROPERTIES

To distinguish organic compounds basing on properties, a flow diagram is used. The flow diagram is uses chemical tests in order to separated unknown organic compounds. The tests derive from the physical and chemical properties specific to a given homologous series. Some of the tests are the solubility test, the bromine test, the acid test, the Fehling's test (copper mirror test), the Brady's test and the Tollen's test (silver mirror test)

IDENTIFICATION TEST TABLE

	CHEMICAL TEST					
RESULT	Solubility in water	Bromine solution	NaOH + phenolphthal ein	2,4 DNPH	Fehling's solution	Tollen's solution
Alkanes	Insoluble	Red/brown	Pink	No colour change	No colour change	No colour change
Alkenes	Insoluble	Colourless	Pink	No colour change	No colour change	No colour change
Alkanols	Soluble	Red/brown	Pink	No colour change	No colour change	No colour change
Alkanoic acids	Soluble	Red/brown	Colourless	No colour change	No colour change	No colour change
Alkanals	Soluble	No colour change	No colour change	An orange precipitate forms	Red precipitate forms	A silver mirror forms
Alkanones	Soluble	No colour change	No colour change	An orange precipitate forms	No colour change	No silver mirror formed

Example

Construct a flow diagram that could be used to identify acetic acid, ethanol, hexene and hexane, using tests that make use of distilled water, bromine solution, sodium hydroxide solution and phenolphthalein indicator.

Solution

